

MUSEUM OF PORTABLE SOUND™

AUDIO CULTURE EXHIBITION SYSTEM™
ONLINE VISITOR GUIDE™

325 SOUND OBJECTS™

NATURAL HISTORY · SCIENCE & TECHNOLOGY
ARCHITECTURE & URBAN DESIGN · ART & CULTURE
FOR ONE TO FIVE LISTENERS

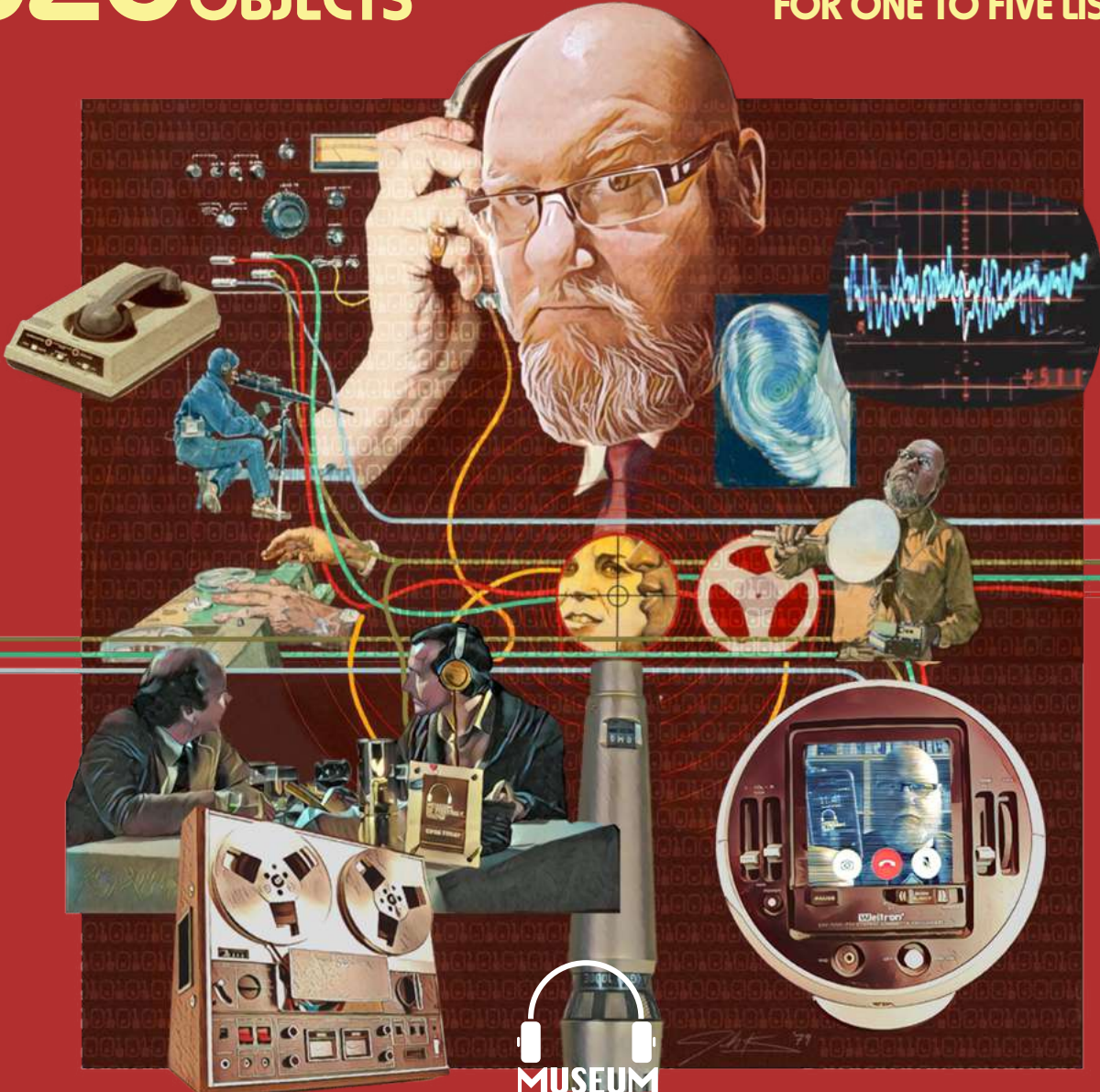

MUSEUM
OF PORTABLE
SOUND



MUSEUM
OF
PORTABLE SOUND
Online

MUSEUM
OF PORTABLE
SOUND
PRESS ▶

The Museum of Portable Sound

is dedicated to the collection, preservation, and exhibition of sounds as objects of culture.

With particular focus on portability, nostalgia, digital materiality, continuing education, critique, and curiosity, we bring the culture of sound to the world – one listener at a time.



Museum of Portable Sound Online Visitor Guide Copyright ©2020 The Museum of Portable Sound & John Kannenberg. All rights reserved. Except where we've blatantly ripped something off, in which case it's a parody or fair use.

10 9 8 7 6 5 4 3 2 1 0

Published in Southsea, UK PO5 3RL

Typeset in ITC Garamond and Proxima Nova (mostly) using Adobe InDesign.

Design, Layout, Photography & Illustration by John Kannenberg unless otherwise noted.

Written by John Kannenberg. Extremely Generous Proofing & Editing Assistance by Tom Parnell.

Cover image by John Kannenberg.

A version of this publication is also available in PDF at museumofportablesound.com for use by our visitors.

Connect with us:

museumofportablesound.com patreon.com/museumofportablesound facebook.com/museumofportablesound twitter.com/museumofportablesound
instagram.com/museumofportablesound youtube.com/c/museumofportablesound [museumofportablesound.bandcamp.com](https://bandcamp.com/museumofportablesound)



A Message From Our Director.....	5
MUSEUM CAMPUS MAP	6
TOUR 1: Highlights from the Permanent Collection	7
TOUR 2: Music	8
TOUR 3: Relaxation	9
TOUR 4: Cairo	10
TOUR 5: Chicago	12
TOUR 6: Lisbon	14
TOUR 7: London	16
TOUR 8: London Museums	18
TOUR 9: Rome & Venice	20
TOUR 10: Chief Curator’s Top 40	22
BONUS TOUR: Recent Acquisitions	24
PERMANENT COLLECTION GALLERIES Guide.....	26
EXPOSITION SPACE TEMPORARY EXHIBITION	
The Record That Went To Space	66
Staff & Contributor Biographies.....	68
Colophon.....	71

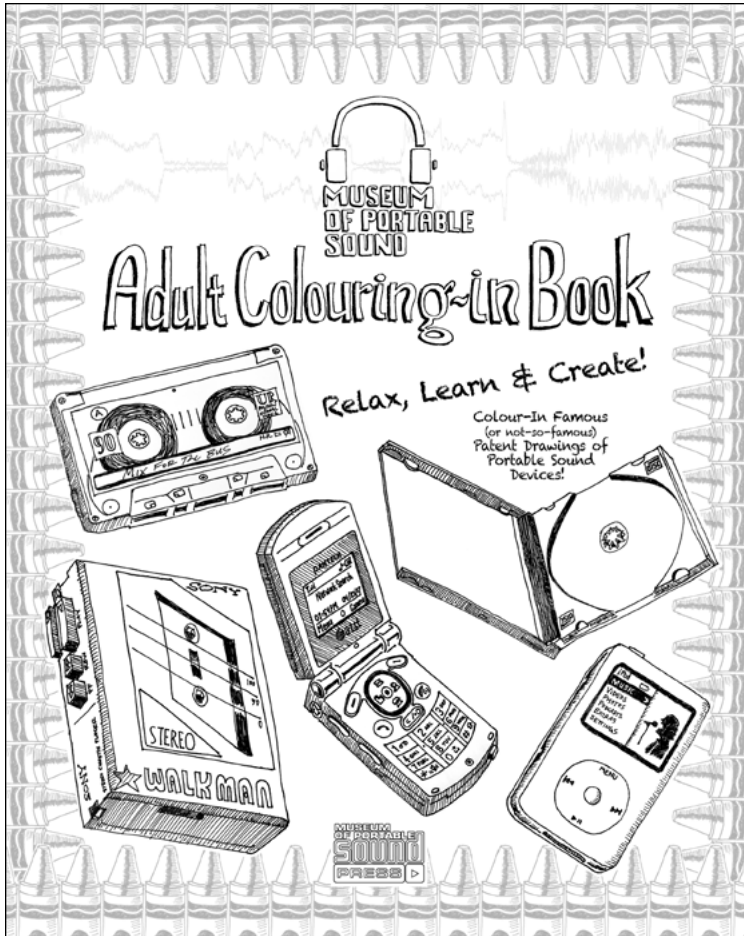

THE MUSEUM OF PORTABLE SOUND ADULT COLOURING-IN BOOK

Relax, learn & create with this unique mixture of stress-free, intuitive time-wasting and an illustrated history lesson! This adult colouring-in book lets you doodle to your heart's content by colouring-in a series of classic patent application drawings of portable sound technologies, from the very beginning of recorded audio up to the present day – each one accompanied by a brief text explaining its significance!

Available at museumofportablesound.com/bookshop



Norio Ohga inserts a pre-recorded Mariah Carey MiniDisc into a MiniDisc Walkman (date unknown).

The Sony Walkman 1979

When Sony co-founders Masaru Ibuka and Akio Morita devised their portable stereo cassette player, they named it the Walkman for the Japanese market – and originally refused to call it that in other countries, because they thought it wouldn't make sense. It was originally called the **Stowaway** in the UK, the **Freestyle** in Australia and Sweden, and the **Soundabout** in the United States. Fortunately, not only did the process of registering multiple trademarks in each country become unruly, but the player became so popular so quickly that the name didn't seem to be a hindrance to anyone buying it – so they gave up and just stuck with Walkman. The original design (top) included two headphone jacks and a microphone – not for recording, but so that two people could listen together and talk to each other, as the microphone broadcast their conversation through the headphones. This initial social aspect of the device never fully caught on: by the time of the Sports Walkman (below), most models only featured a single headphone jack, ushering in a new culture of solitary, cinematic listening that was named 'The Walkman Effect' by Professor Shuhei Hosokawa.

Designer: Norio Ohga

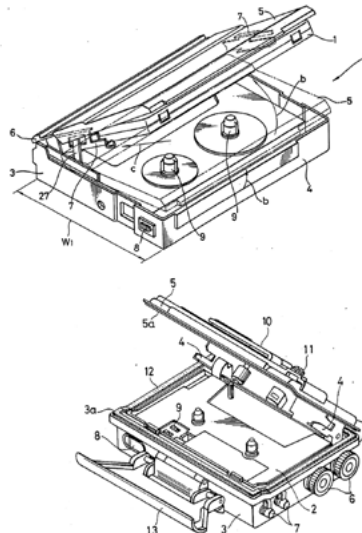

Sample two-page spread from the *Museum of Portable Sound Adult Colouring-In Book*

A MESSAGE FROM OUR DIRECTOR

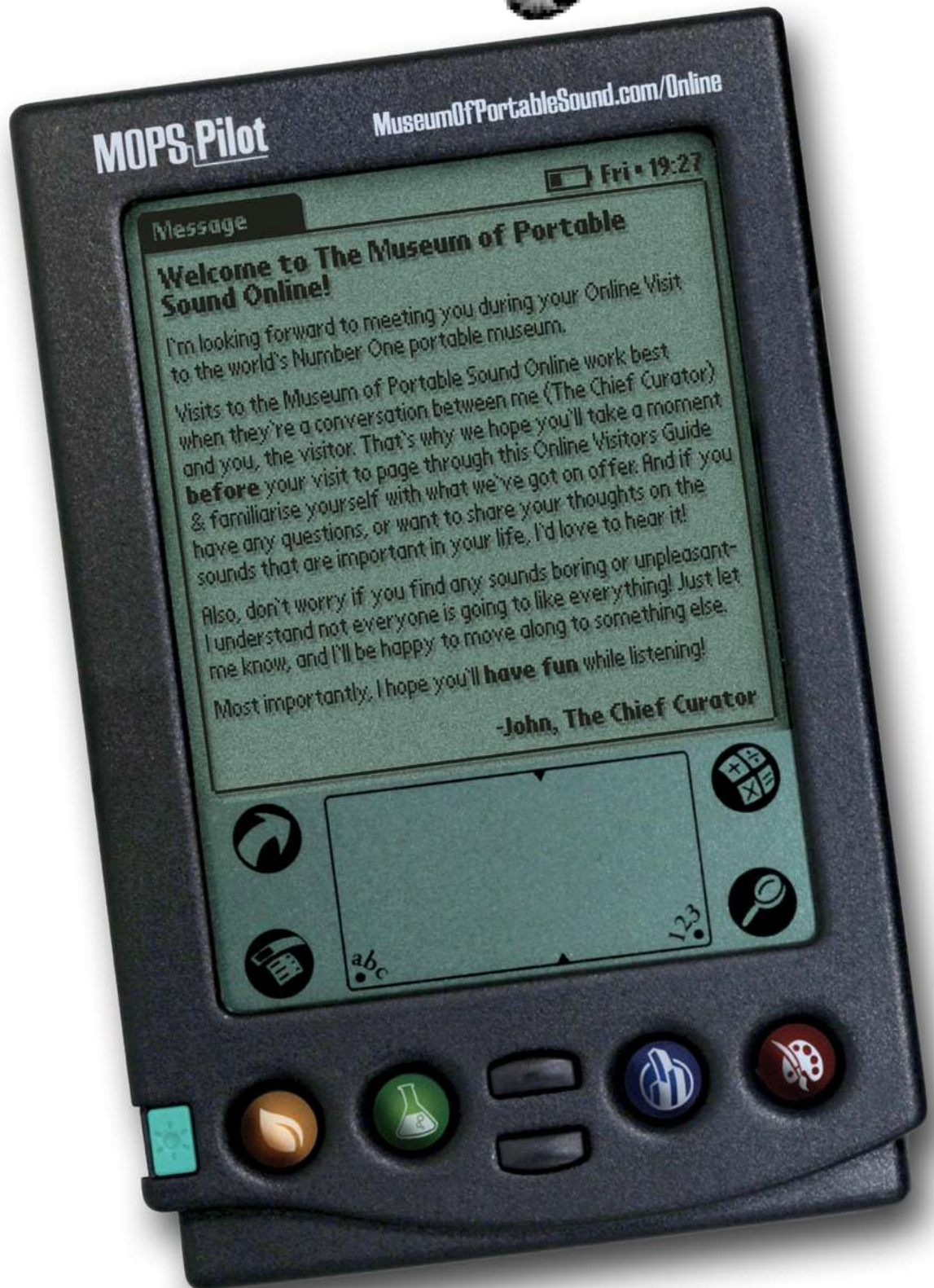

MUSEUM OF PORTABLE SOUND

MUSEUM CAMPUS

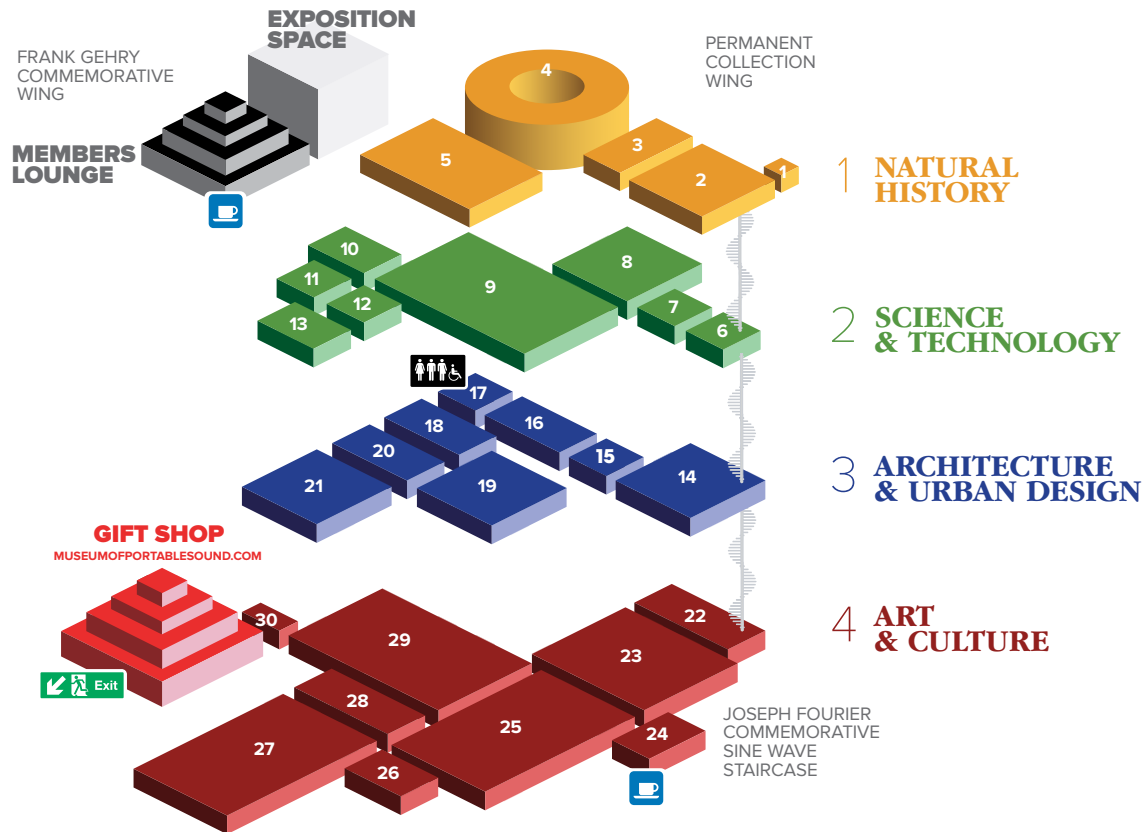

1 NATURAL HISTORY

- 1 **Humans**
- 2 **Animals**
- 3 **Insects**
- 4 **Underwater Life**
- 5 **Weather & Water**

2 SCIENCE & TECHNOLOGY

- 6 **Laboratories & Medicine**
- 7 **Acoustics**
- 8 **History of Audio Recording**
- 9 **Audio Interfaces**
- 10 **Machines**
- 11 **Glitches**
- 12 **20th Century Audio Equipment**
- 13 **21st Century Audio Equipment**

3 ARCHITECTURE & URBAN DESIGN

- 14 **Construction, Exteriors & Tours**
- 15 **Fountains**
- 16 **Doors, Windows & Fixtures**
- 17 **Plumbing, Heating & Cooling**
- 18 **Elevators & Escalators**
- 19 **Interiors**
- 20 **Railway Stations**
- 21 **Walks**

4 ART & CULTURE

- 22 **Archaeology**
- 23 **Art Processes**
- 24 **Food**
- 25 **Transport**
- 26 **Bells & Clocks**
- 27 **Rituals & Events**
- 28 **Libraries & Archives**
- 29 **Museums**
- 30 **Exhibitions of Sounds**

GUIDED TOURS

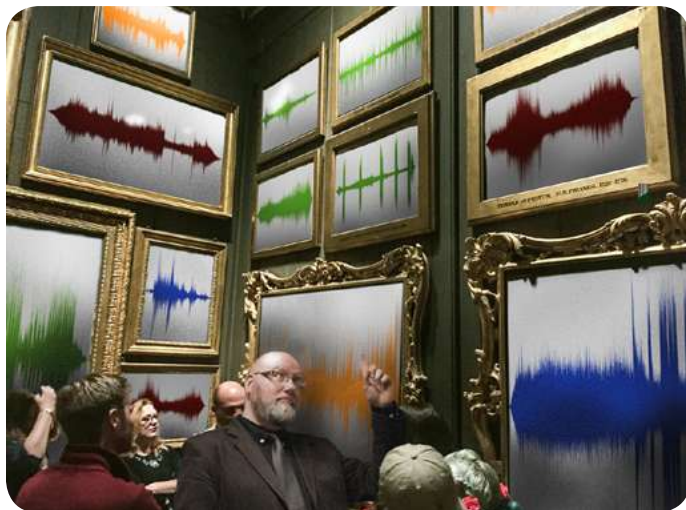

With 325 objects organised into 30 different galleries that take over eight and a half hours to listen to, deciding on where to begin in our **Permanent Collection Galleries** can be more than a little overwhelming!

If you'd like some suggestions, try one of our **Guided Tours!** They have been specially curated to highlight our most important objects – just sit back, relax, and enjoy the tour!

TOUR 1 HIGHLIGHTS FROM THE PERMANENT COLLECTION

*Only have time for a short visit? Make sure to experience some of our favourite objects! **15 minutes*** ⌚



Wake up with a 'Dawn Symphony'—
a tranquil sunrise over Rome

GALLERY 2 OBJECT 1



Chuckle along with a Pink River
Dolphin in the Amazon River

GALLERY 4 OBJECT 5



Hear the First Recorded Human Voice:
a picture of sound etched on paper in 1860

GALLERY 8 OBJECT 1



Cross the street with your eyes closed
in Lisbon, Portugal

GALLERY 9 OBJECT 22



Try to play a broken iPod
at the Apple Store

GALLERY 11 OBJECT 1

Flush Sigmund Freud's toilet
in his house in Vienna

GALLERY 17 OBJECT 1



Sit in the 24,000 square foot Great Hall
inside Chicago's Union Station

GALLERY 19 OBJECT 7



Walk through ancient catacombs
beneath Alexandria, Egypt

GALLERY 22 OBJECT 3



Eat some Pop Rocks®

GALLERY 24 OBJECT 10













Cheer a marching band at San Francisco
Pride the year gay marriage was legalised

GALLERY 27 OBJECT 18













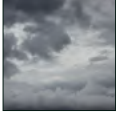

TOUR 2 MUSIC

Listen to objects that contain or are related to music. **20 minutes** ⌚

		DURATION	GALLERY
	The First Recording of a Museum (1888) 4,000-person choir sings Handel in London's Crystal Palace on a wax cylinder.	2.28	8
	The First MP3 (1987): Suzanne Vega, 'Tom's Diner (a capella)' Song used at Fraunhofer Labs, Germany to refine the MP3 algorithm.	2.09	8
	Disco Boat: Nile River, Cairo (2010) A floating party happens every night on the Nile River.	1.08	25
	Madhavi: Gurgaon, India (2016) <i>Balma Mane Na</i> , from 1962 Bollywood film <i>Opera House</i> , sung in praise of Lakshmi.	1.45	27
	Hofbrauhaus: Munich, Germany (2012) <i>Volksmusik</i> (German folk music), lederhosen & ennui at Munich's most famous pub.	2.01	27
	Amolador Flute: Lisbon (2017) recorded by João Caldas Tune played by neighbourhood knife sharpeners to let people know they're ready to work.	0.14	27
	Wedding Music Practice: Maulbronn Monastery, Germany (2012) A man sings and a woman plays organ, preparing for a traditional wedding ceremony.	1.55	27
	Pride Parade: San Francisco (2008) Lesbian marching band performs <i>Chapel of Love</i> the year gay marriage became legal.	1.39	27
	Buskers: District Line Underground Train, London (2017) Jubilant band walks through a Tube train and pauses at the stop.	1.58	27
	Myra, Crete Street Music: Athens (2011) Traditional folk music played by a busker.	1.21	27
	Museum of Mechanical Musical Machines, Portugal (2017) French <i>bastringue piano</i> , used in dance halls, plays music off a cylinder.	1.31	29
	Reverb Chamber: Motown Museum, Detroit (2012) Demonstration of clapping in an attic crawlspace, integral to the Motown sound.	1.08	29

TOUR 3 RELAXATION

Bliss out on a tour of natural, quiet, or calming objects. **20 minutes** 









		DURATION	GALLERY
	Crickets (Daytime): West Park Wetlands, Ann Arbor (2009) Heavy cricket <i>stridulation</i> (rubbing body parts together to generate sound).	1.00	3
	Psithurism: Albufeira, Algarve, Portugal (2016) The sound of wind blowing through tree leaves has a name: <i>psithurism</i> .	2.34	5
	Thunderstorm: Corfu, Greece (2011) A heavy rainfall outside a hotel window.	1.42	5
	Waterfall: Offenburg, Germany (2014) The sound of the highest waterfall in Germany.	2.00	5
	Lake Erie Waves: Pelee Island, Canada (2010) Rhythmic waves lapping back and forth.	2.28	5
	Brown Noise Synthetic sound whose frequencies mimic the randomness of <i>Brownian Motion</i> .	1.00	7
	Buckingham Fountain, Chicago (2005) 14,000 US gallons of water are pumped every 20 minutes in Chicago's Grant Park.	1.30	15
	Fountain, Baden Baden, Germany (2012) Gurgling on a private terrace amidst a winding staircase on the side of a hill.	1.19	15
	Ancient Roman Channel: Winchester, UK (2018) River rerouting that has run continuously since 70CE.	1.30	22
	Tree Trimming: Cairo, Egypt (2010) Soothing sound of shears at the Mahmoud Mukhtar Museum Park.	1.12	23
	Cloisters: Maulbronn Monastery, Germany (2012) Not just bells: listen closely to hear a small string instrument ensemble practising.	1.37	26
	Art Institute of Chicago: Modern Wing (2009) Analogue film projector, part of Wolfgang Plöger's <i>Make No Mistake About This</i> installation.	1.17	29

TOUR 4 CAIRO









Listen to objects collected in Cairo, Egypt. **30 minutes** ⌚

The modern capital of Egypt, Cairo (*Arabic: القاهرة*) was initially settled during the first millennium. The nearby city of Memphis had served as Egypt's capital during the time of the pharaohs; during the 4th century CE, a Roman fortress, Babylon, was built on the banks of the Nile River, now the oldest structure in the modern city. Following the Muslim takeover in 640CE, the city began rapidly expanding, and was established as Cairo in 969CE during the Fatimid dynasty. Today Cairo is a thriving metropolis of over 9 million people, home to the Arab world's largest creative industries.

		DURATION	GALLERY
	Falling Off A Camel Next To The Great Pyramid (2010) Disaster awaits.	0.49	2
	Water Pipes, Toilet (2010) In Rawabet Art Gallery, everyone knows when you've been to the loo.	0.47	17
	Rameses Station (2010) Even while much of it was under renovation, this train station was full of activity.	2.30	20
	Walking In Zamalek (2010) A brisk walk from EuroDeli to the Golden Tulip Flamenco Hotel.	5.18	21
	King Tut's Trumpet (1939) Played in public for the first time in 3,000 years, in the Egyptian Museum at Tahrir Square in a live BBC Radio broadcast.	2.55	22
	Street Engraver (2010) An artist engraves a metal bowl on Al-Muizz Street in the Khan Al-Khalili district.	1.12	23
	Tree Trimming: Cairo, Egypt (2010) Soothing sound of shears at the Mahmoud Mukhtar Museum Park.	1.12	23
	Food Court inside Arkadia Shopping Mall (2010) Pull up a chair and grab a falafel sandwich.	2.00	24

Islamic Cairo viewed from atop a minaret at Al-Azhar, the first mosque in Cairo, which opened in 972CE.













		DURATION	GALLERY
	Train to Cairo from Alexandria (2010) Nescafé or shay? Relax a little on the way back to Cairo in this quiet passenger train.	2.01	25
	Taxi Cab Ride (2010) Listen to the traffic and some NILE FM on the radio.	2.44	25
	Boat Ride to the Nilometer (2010) Artist Reem Gabriel commandeers an old man's boat for an attempted after-hours invasion that ultimately fails.	1.22	25
	Disco Boat on the Nile (2010) A late night floating party, the disco boats of Cairo are a haven for DJs and underground culture.	1.08	25
	Call to Prayer (2010) An afternoon call for Muslims to pray rings out over the busy Talaat Harb street.	1.55	27
	Islamic Chanting, Al-Azhar Mosque (2010) An afternoon prayer ceremony inside Cairo's oldest mosque.	1.59	27
	Downtown Street Market (2010) A quick walk through a bustling street market full of food, clothing, and home goods.	1.36	27

TOUR 5 CHICAGO



Listen to objects collected in Chicago, US. **30 minutes** ⌚











Founded in 1837 on the western shore of the freshwater Lake Michigan, Chicago was built upon swamp-land – so when, about twenty years later, the city needed to build a sewer system to stop the flooding that turned its streets into bacteria-infested cesspools, the entire city was raised up about a metre. Now home to over two and a half million people, Chicago is known for a vibrant art scene, a long history of organised crime and racial segregation, as well as an idiosyncratic (and decadent) ‘deep-dish’ pizza.

		DURATION	GALLERY
	Lake Michigan, Rocky Shore (2005) Relax along the shore of one of the largest freshwater lakes in the world.	2.00	5
	Street Crossing Signal (2004) A chirping, echoing audio signal for the visually impaired, on the campus of the Illinois Institute of Technology.	1.29	9
	Police Siren (2013) Multiple examples of sirens and other Chicago traffic noises heard from the Pritzker Garden outside the Modern Wing of the Art Institute of Chicago.	2.33	9
	Welding, Harold Washington Library entrance (2009) Also: our Acquisitions Team being asked to leave.	0.37	14
	Bridge Rising, Merchandise Mart (2009) The bell signalling a bridge being raised to allow a boat to pass underneath on the Chicago River.	1.32	14
	Architecture Boat Tour (2008) A volunteer tour guide discusses the local architecture along the Chicago River.	1.19	14
	Buckingham Fountain (2005) 14,000 US gallons of water are pumped every 20 minutes in Chicago's Grant Park.	1.30	15
	Steam Heat Radiator (2011) Warming an apartment living room in Albany Park.	1.15	17
	Elevator Down, John Hancock Tower (2009) An elevator that doesn't know when to keep quiet.	0.47	18
	Huettenbar, Lincoln Square (2008) Live German pub music in Chicago's most German neighbourhood.	1.12	19

The Loop is a section of Chicago's elevated train system that encircles the city centre. This is a view of the Loop taken from the Adams Street station.

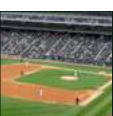

DURATION GALLERY







	The Great Hall, Union Station (2009) The cavernous main space inside Chicago's central train station.	1.31	19
	Amtrak Hiawatha Train Quiet Car (2009) Relax on the way back to Chicago from a day trip to Milwaukee.	1.26	25
	Squeaking Metra Train (2008) Something doesn't sound quite right on this inter-city commuter train.	1.20	25
	Moaning Bus (2008) Something even worse is going on with this downtown bus.	2.00	25
	Water Taxi (2008) Everything's ship-shape with this trip from the Chicago River out along the coast of Lake Michigan.	1.28	25
	Paletero Popsicle Cart (2008) The distinctive bell of a street vendor's popsicle cart wheeling through Albany Park.	1.08	26
	White Sox Baseball Stadium (2009) An afternoon game on the South Side team's home turf.	2.05	27
	4th of July Fireworks (2008) Amateur fireworks celebration on a street in Albany Park.	1.05	27
	Mold-A-Rama® Machine (2012) Moulding a wax model dinosaur inside the Field Museum of Natural History.	1.37	29
	Art Institute of Chicago: Modern Wing (2009) Analogue film projector, part of Wolfgang Plöger's <i>Make No Mistake About This</i> installation.	1.17	29

TOUR 6 LISBON



Listen to objects collected in Lisbon, Portugal. **28 minutes** ⌚

Portugal's capital city of Lisbon (*Portuguese*: Lisboa) is one of the oldest cities in the world. Situated at the mouth of the Tagus River, Lisbon rose to become the heart of a world-spanning colonialist empire whose 16th century 'golden age' might have continued unfettered if not for a city-destroying earthquake in 1755 which led to the creation of seismology. Today Lisbon is known for famous writers like Camões and Fernando Pessoa, its Mediterranean climate, and its heavenly custard tart, the *pastel de nata*.

		DURATION	GALLERY
	Rooster (2016) It's a quiet early morning in the Santa Iria de Azóia neighbourhood and off in the distance, someone's got a rooster.	0.47	2
	Radiology Lab (2015) In the waiting room of a radiology lab, a Brazilian Telenovela is playing on the TV.	1.30	6
	Street Crossing Signal (2017) A high-pitched signal at a traffic light outside Vasco da Gama shopping mall.	2.01	9
	Escalator, Oriente Station (2017) Inside Lisbon's central train station, designed by architect Santiago Calatrava.	1.30	18
	Walking in Graça (2015) A morning walk to buy milk from a local grocer.	10.00	21
	Archaeologists Clearing a Roman Theatre (2015) Discovered in the middle of a busy street, this 4,000-seat theatre was built during the reign of Augustus, sometime between 27BCE and 14CE.	2.00	22

The Castelo de São Jorge, a castle in Santa Maria Maior, sits on a hill that was first fortified in 48BCE. It overlooks the historical city centre of Lisbon.













		DURATION	GALLERY
	No. 28 Trolley at Night (2016) A crowded ride on the city's most popular trolley, featuring Brazilian dance music courtesy of the trolley driver's boombox.	1.56	25
	316 Bus Through Bobadela (2017) As far from hipsters as it's possible to get within the Lisbon city limits.	2.15	25
	Livraria Bertrand, the World's Oldest Operating Bookshop (2016) Bringing <i>peessoas de Lisboa</i> the finest in printed literature since 1732.	1.30	27
	Feira de Ladra Flea Market (2015) One of Lisbon's oldest markets, on the streets of Jardim Boto Machado in Alfama, Feira da Ladra now mainly serves tourists instead of locals.	2.00	27
	Amolador Flute (2017) recorded by João Caldas Tune played by neighbourhood knife sharpeners to let people know they're ready to work.	0.14	27
	Bica Funicular (2019) Steep-hilled electric trolley built in 1892 and declared a national monument in 2002, connecting São Paulo Street to Calhariz Square via Bica de Duarte Belo Street.	3.00	25

TOUR 7 LONDON





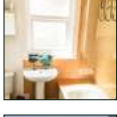





Listen to objects collected in London, UK. **30 minutes** ⌚

The capital of England, London (*Roman*: Londinium) was first settled along the Thames River in 47CE but was replanned and rebuilt about fifty years later. Like Chicago and Lisbon, much of it was destroyed by fire in 1666. It was decimated by bombs dropped by the Nazis during The Blitz of World War II (which makes the success of the city's contemporary best-selling kitchen paper towels, also named Blitz, something of a mystery). Today, London is best known as the birthplace of The Museum of Portable Sound.

		DURATION	GALLERY
	Greylag Geese (2018) A conversation with a goose in St James Park is rudely interrupted.	1.16	2
	Thames River (2015) Waves at night as heard from the South Bank.	2.00	5
	Truck Proximity Alert (2018) Outside BBC Broadcasting House, apparently a truck wants to turn left.	0.37	9
	Airport Announcement, Gatwick (2017) A simple sequence of notes that instantly reminds the listener they are in an airport.	0.10	9
	Fire Truck Siren (2017) A fire truck tries to cut through busy traffic near Westminster Bridge.	0.28	9
	Police Car Siren (2008) A police car passes by along Westminster Bridge.	0.21	9
	Kettle Boiling (1999) An iconic British sound (even though tea was originally brought to the UK by a Portuguese Queen – it's true, look it up #colonialism)	3.00	10
	Malfunctioning Intercom System (2019) It's raining out (of course) and no one can answer the door because the intercom doesn't work.	0.26	11
	Home Water Drainage System (2017) In a typical flat in Catford, someone's just taken a shower – which means there's water running through open pipes on the outside of the building.	1.47	17
	Elevator Up: The Shard (2014) A slightly disturbing 'whispery' audio presentation precedes a ride up what was then the tallest building in the London skyline.	2.58	18

Finding it next to impossible to sum up London in a single photograph, we've opted for this cheesy nighttime view of the Thames.

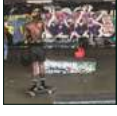

		DURATION	GALLERY
	Victoria Station (2018) Running passengers compete with delay announcements for the listener's attention.	4.33	20
	Tube Train to South Kensington (2018) Includes one of London's best-known soundmarks, the 'Mind The Gap' announcement.	1.50	25
	Bells of Westminster Abbey (2014) A special tune rings out across Westminster on Christmas Day.	1.17	26
	Big Ben's 'Final' Bongs (2017) The bell in Parliament's clock tower rings out noon, its final normal use before a four year shutdown for renovation.	1.28	26
	Shop Owner Banter, Stratford Centre (2013) Market vendors call out for attention in this mall-based street market.	1.13	27
	Friday Night Down The Pub (2018) It's Friday Night, so you know what that means: it's time to join the crowd standing outside your local pub.	1.04	27
	Southbank Undercroft Skatepark (2018) The birthplace of British skateboard culture, currently raising funds for renovation, repair, and the creation of an educational centre.	1.11	27
	Buskers: District Line Underground Train, London (2017) Jubilant band walks through a Tube train and pauses at the stop.	1.58	27
	Bagpipe Busker outside Selfridges (2013) The November Christmas shopping season has just begun, so it's obviously time for some bagpipes.	1.45	27

TOUR 8

LONDON MUSEUMS



Listen to objects collected from London's museums. **20 minutes** 

Although it has primarily become known as the birthplace of the Museum of Portable Sound, there are actually quite a few other museums in London which might be of interest. Covering a wide array of topics from toys to war to fictional detectives, London's museums are, in all seriousness, some of the finest – and also some of the most problematic – in the world. As storehouses of the British Empire's loot, they are wondrous yet deeply flawed reminders of all that is beautiful and evil about humanity.

		DURATION	GALLERY
	The First Recording of a Museum (1888) An Edison Wax Cylinder recording of a 4,000 person choir singing inside the Crystal Palace in Hyde Park.	2.28	8
	Fire Alarm Evacuation at the British Museum (2017) During an academic conference, the British Museum receives a bomb threat and is evacuated in the middle of a researcher's presentation.	2.09	9
	Victorian Toilet, Sherlock Holmes Museum (2013) The sound of an authentic Crap-brand toilet, still in use.	0.11	17
	Escalators, Tate Modern (2015) The central escalators inside the original Bankside power station building.	1.00	18
	Science Museum Sound Equipment Archives (2015) A walk through the section of Blythe House which used to house the Science Museum's collections of sound-related mechanical objects.	3.00	28
	The Guildhall Art Gallery on Fire (2014) A jackhammer goes astray, setting fire to an art museum built above the remains of an ancient Roman amphitheatre.	1.45	29
	Pollocks Toy Museum (2017) Walking through a Victorian home-turned-museum holding objects ranging from an ancient Egyptian wooden toy mouse to entire rooms full of creepy old dolls.	1.30	29

While the obvious choice would have been the British Museum, this image of the interior of the Natural History Museum almost feels more iconically museum-ish.



		DURATION	GALLERY
	Slide Projectors, Hayward Gallery (2013) Standing between a pair of slide projectors that cycle through the works of Ana Mendieta during her retrospective exhibition.	1.00	29
	Florence Nightingale Museum (2017) Pre-recorded background sounds are used throughout the different sections of this museum dedicated to the famous nurse, statistician, and social activist.	1.34	29
	Eames Gravity Xylophone, Barbican (2015) A conceptual musical instrument on display during a retrospective of the work of designers Charles and Rae Eames.	1.14	29
	Grandfather Clock, Sir John Soane's Museum (2013) A clock tensely ticks for a full minute as gallery security paces back in forth trying to get a look at the device in my hand.	1.00	29
	The Prime Meridian, Royal Observatory (2017) Awkwardly standing astride the Prime Meridian so you can hear the sound of one of the Earth's hemisphere's in your left ear, and another hemisphere in your right ear.	1.35	29
	Playing the Rosetta Stone, British Museum (2018) That's actually the touchable copy of the Rosetta Stone, on display in the Enlightenment Galleries, during one of our Listening To Museums class sessions.	1.20	29

TOUR 9







ROME & VENICE



Listen to objects collected in the Italian cities of Rome & Venice. **30 minutes** ⌚

While our Roman and Venetian collections currently lack duration, this combined tour of two of Italy's most famous cities is at no loss for moments of beauty and wonder. The two cities are in many ways opposites: while Rome was founded in 753BCE, Venice's exact origins are lost to time; Rome is built on hills, while Venice is built upon watery canals. Yet they both are brimming with history, tourists, and – not surprisingly – Italian food. And unlike Chicago, the pizza found in these cities is thin and flat.

ROME 12 minutes ⌚

	DURATION	GALLERY
 <p>Dawn Symphony (2017) What it sounds like to wake up in the middle of Rome.</p>	1.08	2
 <p>Ancient Well, San Clemente (2017) A Republican-era water well in the remains of a villa found beneath a 4th century church which itself is underneath a 12th century basilica.</p>	1.45	22
 <p>Morning Espresso (2017) Ordering and drinking an espresso while standing at a typical café counter.</p>	2.01	24
 <p>Bus to Centrale Montemartini (2017) A shaky ride across downtown Rome.</p>	2.21	25
 <p>Sistine Chapel (2017) Want to have a quiet, solemn, spiritual moment? Don't go to the Sistine Chapel.</p>	1.31	29
 <p>Raphael's School of Athens, Musei Vaticani (2017) Want to quietly ponder Raphael's famous ode to Greek philosophy? Do it at home while looking at a photo instead.</p>	2.24	29









Left: Trajan's Column stands above the remains of columns lit at dusk at the Roman Forum.

Right: The sunset from a pier just a short way from the Rialto Bridge, Venice.



VENICE 18 minutes 

DURATION GALLERY

	Public Telephone (2018) Using a pay telephone outside a busy hotel.	0.20	9
	Ventilation Duct (2014) There are few things less suspicious-looking than holding a microphone over your head to record air escaping a vent outside someone's house on a busy street.	1.04	17
	Wine Service, Trattoria Anzolo Raffaele (2018) Frozen grapes in the bottom of a wine glass? Sign us up!	1.07	24
	Cleaning the Mercato di Rialto (2018) Power-washing Venice's famous fish market.	1.20	24
	Waterbus (2018) It's a boat! It's a bus! It's a boat <i>AND</i> a bus!	3.13	25
	Boat in a Canal (2014) As common in Venice as cars are in London.	2.08	25
	St Geremia Tower Clock (2018) The inner mechanism of one of the oldest functioning clocks in Europe.	1.22	26
	Museo di Storia Naturale di Venezia Bibliothec (2018) The tiny single-room library in a museum of natural history.	1.12	28
	Art or Sound, Fondazione Prada (2014) An exhibition of (mostly) European mechanical objects that make sound.	2.30	30

TOUR 10

POSITION	GALLERY	OBJECT NO.	GUIDE PAGE	TITLE DURATION OF OBJECT	LOCATION DATE OF RECORDING
Compiled from the personal aesthetic preferences of the Director & Chief Curator particularly if the recording is funny, exciting, or sentimental.					
				TOTAL DURATION: 58 MINUTES ↻	
1	2	13	31	FALLING OFF A CAMEL (0.49)	★★ No. 1 ★★ BASED ENTIRELY UPON PERSONAL BIAS GREAT PYRAMID, GIZA, EGYPT 1 May 2010
2	27	18	201	PRIDE PARADE MARCHING BAND (1.39)	SAN FRANCISCO, US 6 July 2008
3	24	10	156	POP ROCKS® (1.32)	LONDON 6 June 2017
4	9	7	75	AUTOMATED PORTRAIT BOOTH (2.34)	NAVY PIER, CHICAGO 28 October 2006
5	23	9	149	TREE TRIMMING (1.12)	CAIRO, EGYPT 6 May 2010
6	10	2	83	SECURITY X-RAY SCANNER (1.31)	SKYGARDEN, LONDON 8 November 2017
7	5	2	42	PSITHURISM (2.34)	ALBUFEIRA, ALGARVE, PORTUGAL 8 September 2016
8	29	6	228	GUILDHALL ART GALLERY ON FIRE (1.45)	LONDON 8 March 2014
9	9	8	75	AIRPORT ANNOUNCEMENT (0.10)	GATWICK AIRPORT, LONDON 8 April 2015
10	29	5	227	MUSEUM OF BROKEN RELATIONSHIPS (1.00)	ZAGREB, CROATIA 25 September 2015
11	25	34	178	HOVERCRAFT (3.46)	THE ISLE OF WIGHT, UK 25 September 2018
12	22	3	140	CATACOMBS OF KOM EL-SHAQOUFA (1.59)	ALEXANDRIA, EGYPT 11 May 2010
13	9	22	79	STREET CROSSING SIGNAL (0.56)	VASCO DA GAMA MALL, LISBON 11 October 2004
14	25	22	170	NO. 28 TROLLEY (NIGHT) (1.56)	LISBON, PORTUGAL 1 March 2008
15	29	26	239	ECHO CHAMBER (1.08)	MOTOWN MUSEUM, DETROIT 13 June 2012
16	26	10	189	ST GEREMIA TOWER CLOCK (1.22)	ST GEREMIA, VENICE 23 May 2018
17	9	1	73	PUBLIC TELEPHONE (0.26)	ZAGREB, CROATIA 25 September 2015
18	17	2	113	WATER PIPES AND TOILET (0.47)	RAWABET, CAIRO, EGYPT 17 May 2010
19	29	23	237	PLAYING THE ROSETTA STONE (1.20)	BRITISH MUSEUM, LONDON 19 May 2018
20	3	2	35	CRICKETS (NIGHT) (2.00)	GRABEN NEUDORF-NORD, GERMANY 18 August 2012

POSITION	GALLERY	OBJECT NO.	GUIDE PAGE	TITLE DURATION OF RECORDING	LOCATION DATE OF RECORDING
21	27	32	209	DUELLING BUSKERS (1.42)	SOUTH BANK, LONDON 3 October 2014
22	16	4	111	DOOR (0.06)	NEUE STAATSGALERIE STUTTART 17 October 2012
23	9	9	76	FIRE ALARM, ACADEMIC CONFERENCE (2.09)	BRITISH MUSEUM, LONDON 21 July 2017
24	11	3	89	BROKEN P.A. SPEAKER (0.49)	MITCHELL HALL, UW-MILWAUKEE, US 1 March 2008
25	29	7	228	SISTINE CHAPEL (1.31)	ROME 10 April 2017
26	5	1	41	AUTUMN LEAVES FALLING (2.00)	NORTH PARK NATURE CENTER, CHICAGO 18 October 2008
27	20	5	129	AUTOMATED TRACK ANNOUNCEMENTS (2.55)	UNION STATION, CHICAGO 21 March 2009
28	25	27	173	316 BUS THROUGH BOBADELA (2.15)	LISBON, PORTUGAL 22 September 2017
29	24	2	151	RICE KRISPIES® (3.26)	FACEBOOK LIVE 14 December 2018
30	23	4	146	STREET ARTISTS PAINTING A MURAL (1.30)	SOUTHSEA, UK 9 September 2018
31	29	15	232	PINBALL HALL OF FAME (1.00)	LAS VEGAS, NEVADA, US 28 February 2011
32	2	11	30	SQUIRREL CHASE (0.09)	EVANSTON, IL, US 16 April 2005
33	27	6	196	STREET SWEEPING PUB WORKER (1.31)	APPENWEIER, GERMANY 8 September 2012
34	25	20	169	WUBBLY NO. 26 TRAM (2.30)	VIENNA, AUSTRIA 6 December 2017
35	27	10	197	ROLLER COASTER (1.45)	CENTREVILLE ISLAND, ONTARIO, CA 1 August 2009
36	9	5	74	APARTMENT SECURITY SYSTEM (0.50)	WARSAW, POLAND 8 May 2017
37	29	11	230	MOLD-A-RAMA® MACHINE (1.17)	FIELD MUSEUM, CHICAGO 1 January 2012
38	16	1	109	DOORBELL, PRIVATE RESIDENCE (0.13)	MILWAUKEE, WI, US 1 March 2008
39	27	30	208	VIOLIN VS CONSTRUCTION SAW (0.46)	PARK GÜELL, BARCELONA, SPAIN 16 December 2017
40	29	22	237	THE PRIME MERIDIAN (1.35)	GREENWICH, UK 3 November 2017

BONUS TOUR

RECENT ACQUISITIONS

New objects that have yet to be added to the Permanent Collection Galleries. **13 minutes** ⌚

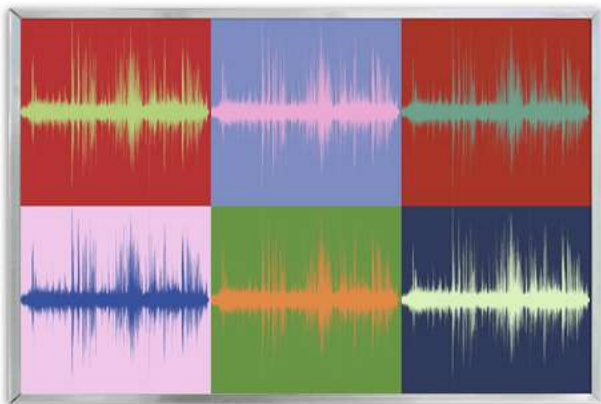

Andy Warhol in a Supermarket (1965, 0.54)
Recorded by Andy Warhol, New York, 16 July 1965.

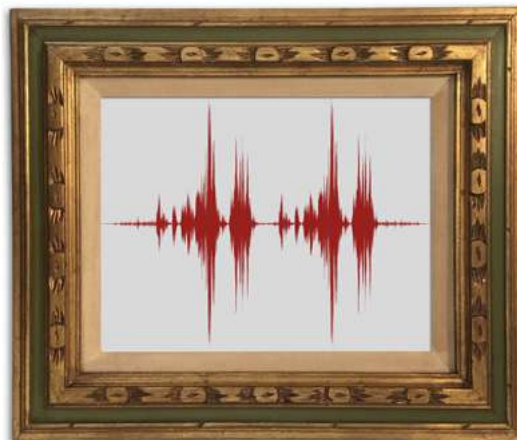

Afilador Whistle (2020, 0.13)
Traditional neighbourhood bandyman signal recorded by Guadalupe Martínez García, Xalapa, Mexico.

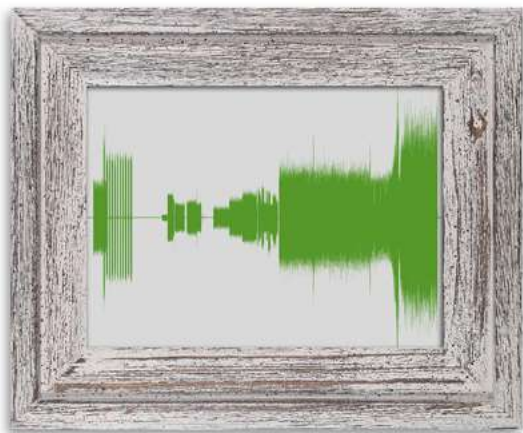

Dialup Modem Handshake (1999, 0.29)

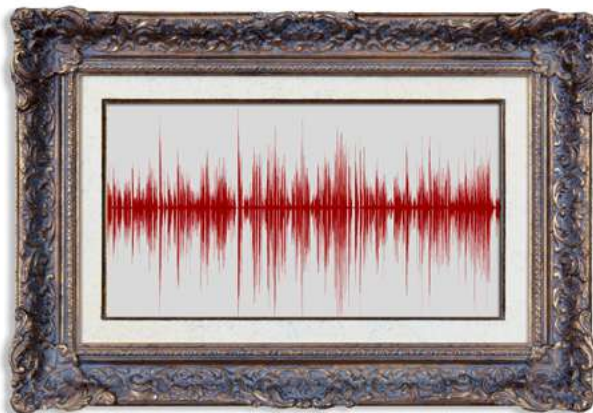

Basil Rathbone Reads The Bells
by Edgar Allen Poe
(1958, 4.06)



iPod Classic Clickwheel
(2020, 0.20)

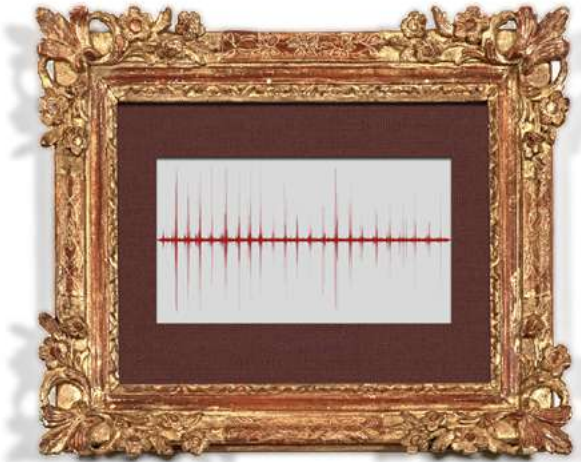

**T.G. Wilfong Turning the Pages of
*Description de l'Égypte*** (2012, 2.07)
*Folio printed 1809, recorded at the Kelsey
Museum of Archaeology, Ann Arbor, Michigan.*



**Bica Funicular, Lisbon,
Portugal** (2019, 3.00)

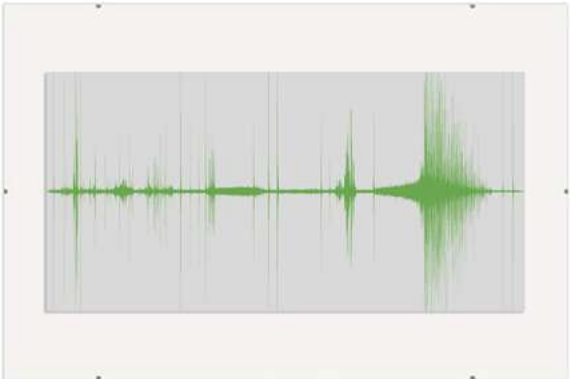

**Studer A807 Mk1 Reel to Reel
Tape Machine** (2019, 1.20)
*Vintage 1981 machine used at
The Keep Archive, Brighton, UK.*



**MUSEUM
OF PORTABLE
SOUND**

**THE
PERMANENT COLLECTION
GALLERIES**



OBJECT LIST

NATURAL HISTORY

Humans

DURATION 18 seconds 

1

01 **Prenatal Infant Heartbeat** Edinburgh (2018)**SOME TIPS
TO HELP GET THE MOST
OUT OF YOUR VISIT**

- **Wear headphones if you can.**
- **If something sounds interesting, ask our Curator about it – he’s happy to tell stories about our objects!**

(Also, look for the Ask Our Curator signs like the one above right – those mean there’s a lot more to learn!)

- **Share your experience! We think our whole museum is one big Selfie Zone – let your friends & family know you visited a museum of sounds today!**



NATURAL HISTORY

Animals

DURATION 15 minutes 

2

- 01 **Dawn Symphony** Rome, Italy (13 Apr 2017)
- 02 **Rooster** Lisbon, Portugal (22 May 2016)
- 03 **World's Oldest Recording of Birdsong**
Actual Bird Record made by a Captive Nightingale (1910)
- 04 **Greylag Geese** St James Park, London (12 Sept 2018)
- 05 **Chickens** Luke's Barn, Michigan (20 Feb 2010)
- 06 **Birds, Crickets, Cows at Dusk** Alandroal, Portugal (30 Apr 2016)
- 07 **Black-Headed Gulls** Portsmouth (20 April 2019)
- 08 **Loon** Minocqua, Wisconsin (24 July 2000)
- 09 **Pardais Birds** Lagos, Portugal (17 Sept 2017)
- 10 **Parrots** Park Güell, Barcelona (3 Dec 2017)
- 11 **Squirrel Chase** Evanston (16 April 2005)
- 12 **Horses** Setúbal, Portugal (23 Sept 2017)
- 13 **Falling off of a Camel** Great Pyramid, Giza, Egypt (1 May 2010)
- 14 **Bat Echolocation (slowed)** Central New Mexico (July 2017)
- 15 **Bat Emergence (5% slowed)** Central New Mexico (July 2017)

NATURAL HISTORY

Insects

DURATION 5 minutes 

3

- 01 **Crickets (day)** Wetlands, West Park, Ann Arbor (14 Sept 2009)
- 02 **Crickets (night)** Train Station, Graben Neudorf Nord (18 Aug 2012)
- 03 **Bee** Catford, London (20 Aug 2017)
- 04 **Cicadas** Corfu, Greece (2 Oct 2011)

NATURAL HISTORY

Underwater Life

DURATION 9 minutes 

4

- 01 **Aquatic Insects** Logan River, Queensland (Date Unknown)
- 02 **Freshwater Snapping Shrimp** Noosa River, Queensland (11 May 2015)
- 03 **White Beaked Dolphin** North Sea, UK (04 Oct 2015)
- 04 **Australian Humpback Dolphins** Tin Can Bay, Queensland (20 Jan 2017)
- 05 **Pink River Dolphins** Amazon River, Brazil (28 Oct 2011)
- 06 **Humpback Whales** Gold Coast, Queensland (3 Sept 2018)

**Meet Dr Leah Barclay,
who recorded these
sounds!**

Leah Barclay is an acclaimed bioacoustician, artist, and researcher who contributed sounds from her massive archive of underwater recordings. Learn more about her work at her website:

leahbarclay.com

NATURAL HISTORY

Weather & Water

DURATION 27 minutes 

5

- 01 **Autumn Leaves Falling** Chicago (18 Oct 2008)
- 02 **Psithurism** Albufeira, Algarve, Portugal (8 Sept 2016)
- 03 **Rain and tornado warning siren** Albany Park, Chicago (5 Aug 2008)
- 04 **Rain and tornado warning siren** Ann Arbor, Michigan (6 June 2010)
- 05 **Thunderstorm** Corfu, Greece (7 Oct 2011)
- 06 **Bloemenmarkt Rain** Amsterdam (28 Feb 2010)
- 07 **Café Downpour** Paris Est Rail Station (26 Sept 2012)
- 08 **Creek** Park of the Senses, Schwarzwald, Germany (14 Sept 2014)
- 09 **The River Thames** London (3 March 2015)
- 10 **Waterfall** Offenburg, Germany (14 Sept 2014)
- 11 **Lake Michigan Rocky Shore** Chicago (7 Sept 2005)
- 12 **Lake Erie waves** Pelee Island, Canada (2 July 2010)
- 13 **Birket Qarun** Fayoum, Egypt (19 May 2010)
- 14 **Clarence Esplanade Beach** Southsea, UK (28 Sept 2018)



Psithurism?!? Is that even a real word?

Our Curator can tell you all about the mysterious word **psithurism** – you'll never walk through a forest the same way again!

DURATION 4 minutes 

- 01 **Radiology Lab** Lisbon, Portugal (10 Apr 2015)
- 02 **Intravenous Tube Regulator** Evanston, Illinois, US (13 Apr 2014)
- 03 **Root Canal Smiles For You** Brockley, London (10 Feb 2018)

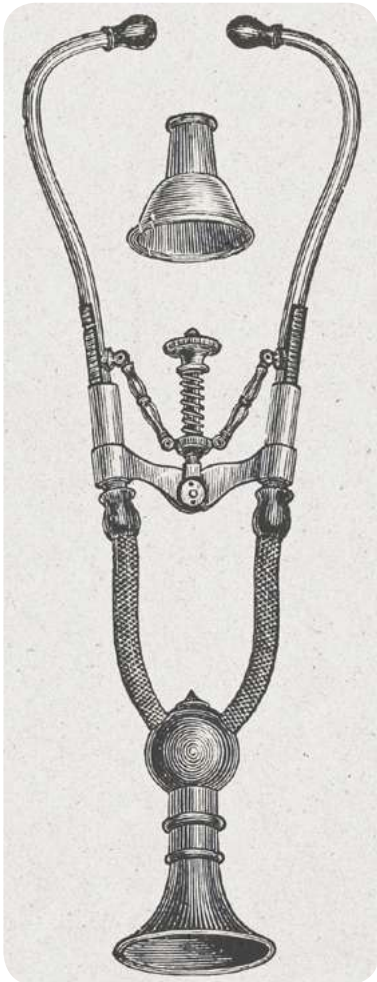

The stethoscope – medicine’s listening tool – was invented in Paris in 1816. And one of its earliest versions was shaped like a top hat!

Our Curator can tell you lots more about the history of the stethoscope – ask away!



SCIENCE & TECHNOLOGY

Acoustics

DURATION 12 minutes 

7

01 **Reverberation Chamber** Columbia College, Chicago (9 July 2010)02 **Anechoic Chamber** London South Bank University (23 July 2015)

THE NOISE SPECTRUM

03 **White Noise** (2019)04 **Pink Noise** (2019)05 **Brown Noise** (2019)06 **Blue Noise** (2019)07 **Purple Noise** (2019)08 **Grey Noise** (2019)**Wait a minute – sounds have colours?**

Our Curator can tell you lots more about these objects – ask away!



LISTENING CLOSE-UP

The Noise Spectrum

What's your favourite colour?

A soundwave has two main characteristics: its **frequency** (how fast it vibrates in one second, with one vibration per second equal to a standard unit of measurement known as a **hertz**) and its **amplitude** (their power, or physical size of the waves).

Generally, **musical** sounds have frequencies that are pleasing to the ear and spaced at regular intervals, while **non-musical** sounds – a door slam, a footstep – are soundwaves with random distributions of frequency and amplitude.

The sounds in the 'noise spectrum' also contain random distributions of frequency and amplitude. However, unlike a door slam, they're a continuous tone – able to drone on and on forever. Some of them may be unpleasant, but some of these noises can actually be used therapeutically, to induce relaxation or sleep.

The **synthesised** sounds in the noise spectrum do not occur in nature. Their 'colours', for the most part, take their names from the type of light that the behaviour of their waves most resembles. So **white noise**, for example, contains every frequency of sound, just like **white light** contains every frequency of light.

SCIENCE & TECHNOLOGY

History of Audio Recording

DURATION 11 minutes

8

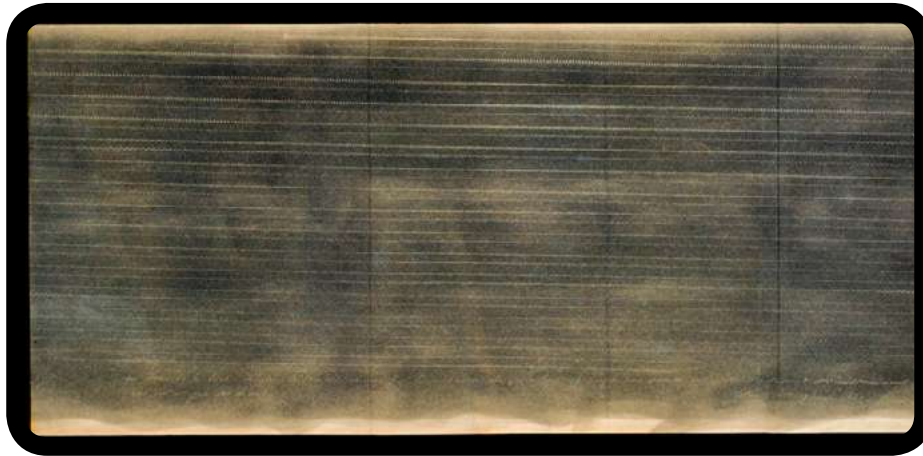

The first recording of a human voice was made with this picture – the world just didn't figure out how to listen to it until 2008.



There's cool story about this object!

- 01 **The First Recording of a Human Voice** Paris (9 Apr 1860)
- 02 **The First Recording of a Museum** The Crystal Palace, London (1888)
- 03 **The First Binaural Pop Album** Lou Reed's *Street Hassle* (1978)
- 04 **The First CD, Track 6** Claudio Arrau performs Chopin Japan (1980)
- 05 **The First MP3** Suzanne Vega *Tom's Diner (a capella)* (1987)



We've got the world's first Compact Disc!

This copy of Claudio Arrau's Chopin Waltzes held in the Physical Objects Collection of The Museum of Portable Sound.

Ask to take a look at it during your Online Visit!

MUSEUM OF PORTABLE SOUND

mp3@25

The Anniversary Exhibition 1995-2020

MUSEUMOFPORTABLESOUND.COM/MP3

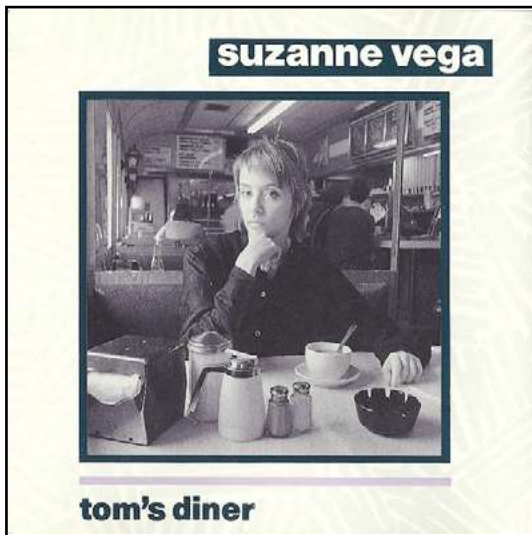

Learn the full story behind Suzanne Vega's connection with the invention of the MP3!

We launched our first FREE online exhibition, **MP3@25**, on the 25th anniversary of the creation of the MP3 digital audio file type.

Discover the story of how compressed digital audio changed the world!
Enter the exhibition at:
museumofportablesound.com/mp3

SCIENCE & TECHNOLOGY

Audio Interfaces

DURATION 29 minutes 

9

- 01 **Public Telephone** Zagreb (25 Sept 2015)
- 02 **Public Telephone** Venice (24 May 2018)
- 03 **Utility Telephone** Chicago (2 May 2009)
- 04 **ATM** San Francisco (5 July 2008)
- 05 **Apartment Security System** Warsaw, Poland (8 May 2017)
- 06 **Truck Proximity Alert** London (19 April 2018)
- 07 **Automated Portrait Booth** Chicago (28 Oct 2006)
- 08 **Airport Announcement** Gatwick Airport (8 April 2015)
- 09 **Alarm Test** UC-Berkeley campus (2 July 2008)
- 10 **Fire Alarm Evacuation** British Museum, London (21 July 2017)
- 11 **Foghorn Conversation** Portsmouth, UK (16 Oct 2018)

Street Crossing Signals for the Visually Impaired:

- 12 **IIT Campus, Chicago** (11 Oct 2004)
- 13 **Port of San Francisco** (5 Jul 2008)
- 14 **Ann Arbor, US** (14 June 2009)
- 15 **Toronto, Canada** (31 July 2009)
- 16 **Munich, Germany** (20 Oct 2012)
- 17 **Zagreb, Croatia** (26 Sept 2015)
- 18 **Aarhus, Denmark** (5 June 2016)
- 19 **Warsaw, Poland** (6 May 2017)
- 20 **Antwerp, Belgium** (3 Aug 2017)
- 21 **Vienna, Austria** (9 Dec 2017)
- 22 **Lisbon, Portugal** (23 Dec 2017)
- 23 **Tampere, Finland** (12 June 2018)

- 24 **Fire Truck Siren** London (8 Aug 2017)
- 25 **Police Car Siren** London (8 Aug 2017)
- 26 **Police Car Siren** Ghent (22 July 2017)
- 27 **Police Car Sirens** Chicago (14 June 2013)

LISTENING CLOSE-UP

Soundmarks

*What we hear
is where we are*

Objects 12–23 make up a collection of audio interfaces that help visually impaired people cross the street. The sounds are heard when users press buttons at the crosswalk. Some of the signals use language, others use abstract clicks or beeps. Although many of the signals may sound similar, each is unique.

R. Murray Schafer, a Canadian composer and researcher, coined the term **soundmark** for sounds that give communities their 'acoustic identity.' Do you think these traffic signals might be soundmarks? How might these sounds reflect the local culture of each city? What are some soundmarks in your neighbourhood?

SCIENCE & TECHNOLOGY

Machines

10

DURATION 14 minutes 

- 01 **Kettle** South Kensington, London (Oct 1999)
- 02 **Security X-Ray Conveyor** London (8 Nov 2017)
- 03 **Jackhammer** Portsmouth, UK (10 Oct 2018)
- 04 **Geiger Counter** Las Vegas (2 March 2011)
- 05 **Cable Car Underground Guide Cable** San Francisco (5 July 2008)
- 06 **Refrigeration Unit** Speyer, Germany (18 Aug 2012)
- 07 **Portable Generator** Chicago (24 Aug 2008)
- 08 **Portable Generator** Kenosha, Wisconsin (18 April 2009)
- 09 **Portable Generator** Detroit (17 Oct 2009)
- 10 **Portable Generator** Southsea, UK (15 Sept 2018)

SCIENCE & TECHNOLOGY

Glitches

DURATION 6 minutes 

11

- 01 **Malfunctioning iPod** Apple Store, Chicago (5 Aug 2008)
- 02 **Malfunctioning MacBook** Apple Store, Chicago (8 Sept 2008)
- 03 **Broken P.A. Speaker** Mitchell Hall, UW–Milwaukee (1 Mar 2008)
- 04 **Broken Fire Alarm** Pierpont Commons, Univ. of Michigan (19 Jun 2009)
- 05 **Malfunctioning Intercom** London (4 April 2019)
- 06 **PLAY Exhibition Glitch** The Henry Ford, Detroit (16 Aug 2010)

SCIENCE & TECHNOLOGY

20th Cent. Audio Equipment

12

DURATION 6 minutes 

- 01 **Dansette Hi-Fi model Phonograph** London (17 Sept 2016)
- 02 **Panasonic RQ-L317 Cassette Recorder (1980s)** London (17 Sept 2016)
- 03 **TapeTalk 2** Minneapolis (29 Nov 2017)

Who invented the modern microphone?

Our Curator can introduce you to Dr James West, the man responsible for the technology that made our museum possible!



SCIENCE & TECHNOLOGY

21st Cent. Audio Equipment

13

DURATION 6 minutes 

- 01 **Arcam Solo CD Player** London (17 Sept 2016)
- 02 **iPod Classic magnetic field** London (2015)
- 03 **iPhone 4S magnetic field** London (2015)
- 04 **Zoom H2 magnetic field** London (2015)
- 05 **Olympus LS-10 magnetic field** London (2015)

How do you record a magnetic field?

Our Curator can tell you about **Electromagnetic Induction**, a way to reveal the hidden sounds of electronic devices that are constantly happening all around you!

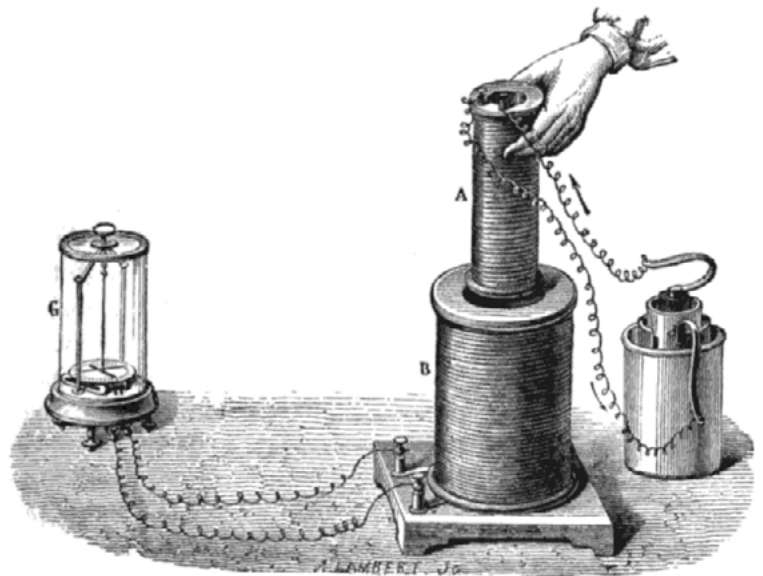

ARCHITECTURE & URBAN DESIGN

Construction, Exteriors & Tours

14

DURATION 10 minutes 

- 01 **Crane Operators** Porto, Portugal (11 Sept 2017)
- 02 **Construction of Apple retail store** Michigan Ave, Chicago (22 Apr 2009)
- 03 **Welding** Newbury Library, Chicago (14 June 2009)
- 04 **Construction destruction** Baku, Azerbaijan (5 Oct 2017)
- 05 **Bridge Rising** Wisconsin Avenue, Milwaukee (4 Sept 2005)
- 06 **Bridge Rising** Merchandise Mart, Chicago (29 May 2009)
- 07 **Architecture Boat Tour** Chicago River, Chicago (5 July 2008)

ARCHITECTURE & URBAN DESIGN

Fountains

DURATION 7 minutes 

15

- 01 **Buckingham Fountain** Chicago 7 (Sept 2005)
- 02 **Fountain** Baden Baden, Germany (23 Aug 2012)
- 03 **Fountain (with explosion?)** Zagreb, Croatia (26 Sept 2015)
- 04 **Sprinklers** Evanston, Illinois (7 Sept 2005)
- 05 **Sprinklers** Karlsruhe, Germany (4 Sept 2012)

ARCHITECTURE & URBAN DESIGN

Doors, Windows & Fixtures

16

DURATION 2 minutes 

- 01 **Doorbell** Milwaukee, Wisconsin (1 Mar 2008)
- 02 **Door** Rubens House, Ghent (21 July 2017)
- 03 **Door** DeBalie Café, Amsterdam (28 Feb 2010)
- 04 **Door** Neue Staatsgalerie, Stuttgart (17 Oct 2012)
- 05 **Window** Bay View, Milwaukee, Wisconsin (27 Apr 2007)

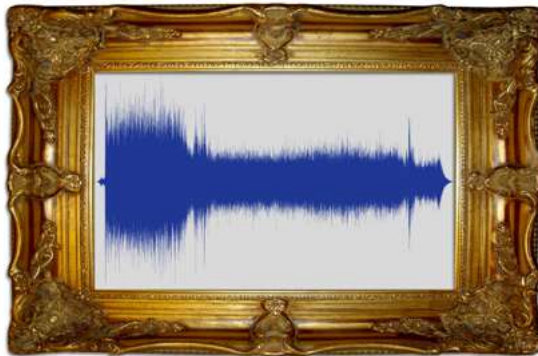
DURATION 17 minutes 

The Shape of the Sound of Sigmund Freud's Toilet

The waveform you see at left is an **unaltered** visual representation of the sound made by Freud's toilet at his home in Vienna. We did nothing to enhance its shape.

Any images this shape conjures up for you is a result of your own neuroses.

- 01 **Sigmund Freud's Toilet** Vienna (9 Dec 2017)
- 02 **Water Pipes, Toilet** Rawabet, Cairo (17 May 2010)
- 03 **Victorian Toilet** London (25 Nov 2013)
- 04 **Drain pipe (outdoor)** Baku, Azerbaijan (3 Oct 2017)
- 05 **Drainage System & Shower** London (8 Aug 2017)
- 06 **Steam Heat Radiator** Chicago (1 Oct 2008)
- 07 **Ventilation Duct** Venice, Italy (3 Nov 2014)
- 08 **Air Vent** Windsor, Ontario, Canada (12 Apr 2010)
- 09 **Ventilation Fan, Coffeeshop** Amsterdam (5 Mar 2010)
- 10 **Air Vent behind Yoshi's** Ann Arbor, US (23 Aug 2009)
- 11 **Central Heating System Vent** Ann Arbor, US (20 Feb 2010)
- 12 **Air Vent** Toledo Mud Hens Baseball Stadium, Toledo, US (1 July 2009)
- 13 **Air Vent** National Stadium, Warsaw, Poland (6 May 2017)
- 14 **HVAC** Ashmolean Museum, Oxford (8 Sept 2015)

ARCHITECTURE & URBAN DESIGN

Elevators & Escalators

18

DURATION 9 minutes 

- 01 **Elevator Up** The Shard, London (24 March 2014)
- 02 **Elevator Down** Hancock Tower, Chicago (2 May 2009)
- 03 **Elevator Up** Tampere Tower, Tampere, Finland (13 June 2018)
- 04 **Escalators** Tate Modern, London (22 Feb 2015)
- 05 **Escalator** St Lazare Metro Station, Paris (Oct 2012)
- 06 **Escalator** Oriente Station, Lisbon (22 Sept 2017)

ARCHITECTURE & URBAN DESIGN

Interiors

DURATION 9 minutes 

19

Sound and Space

Listen to the objects in this gallery straight through, from start to finish, with your eyes closed. Try to pick up clues within the sounds that might indicate how large each space is. What is it about the sounds that allows you to imagine the size of the place where each recording was made?

- 01 **Huettenbar** Lincoln Square, Chicago (10 July 2008)
- 02 **Café York**, UK (April 2002)
- 03 **Entering Flat and Locking Flat Door** Warsaw (8 May 2017)
- 04 **Deserted House After Tornado** Dundee, Michigan (8 June 2010)
- 05 **Swimming Pool** Hotel Intercontinental, Chicago (27 Aug 2007)
- 06 **Sacre Coeur** Paris (24 Sept 2012)
- 07 **The Great Hall** Union Station, Chicago (21 Mar 2009)

Railway Stations



DURATION 16 minutes 

- 01 **Victoria Station** London (3 Dec 2018)
- 02 **Tampere Station** Tampere, Finland (14 June 2018)
- 03 **Ramses Station** Cairo (8 May 2010)
- 04 **Centraal Station** Amsterdam (24 Feb 2010)
- 05 **Union Station** Chicago (21 March 2009)

ARCHITECTURE & URBAN DESIGN

Walks

DURATION 33 minutes 

21

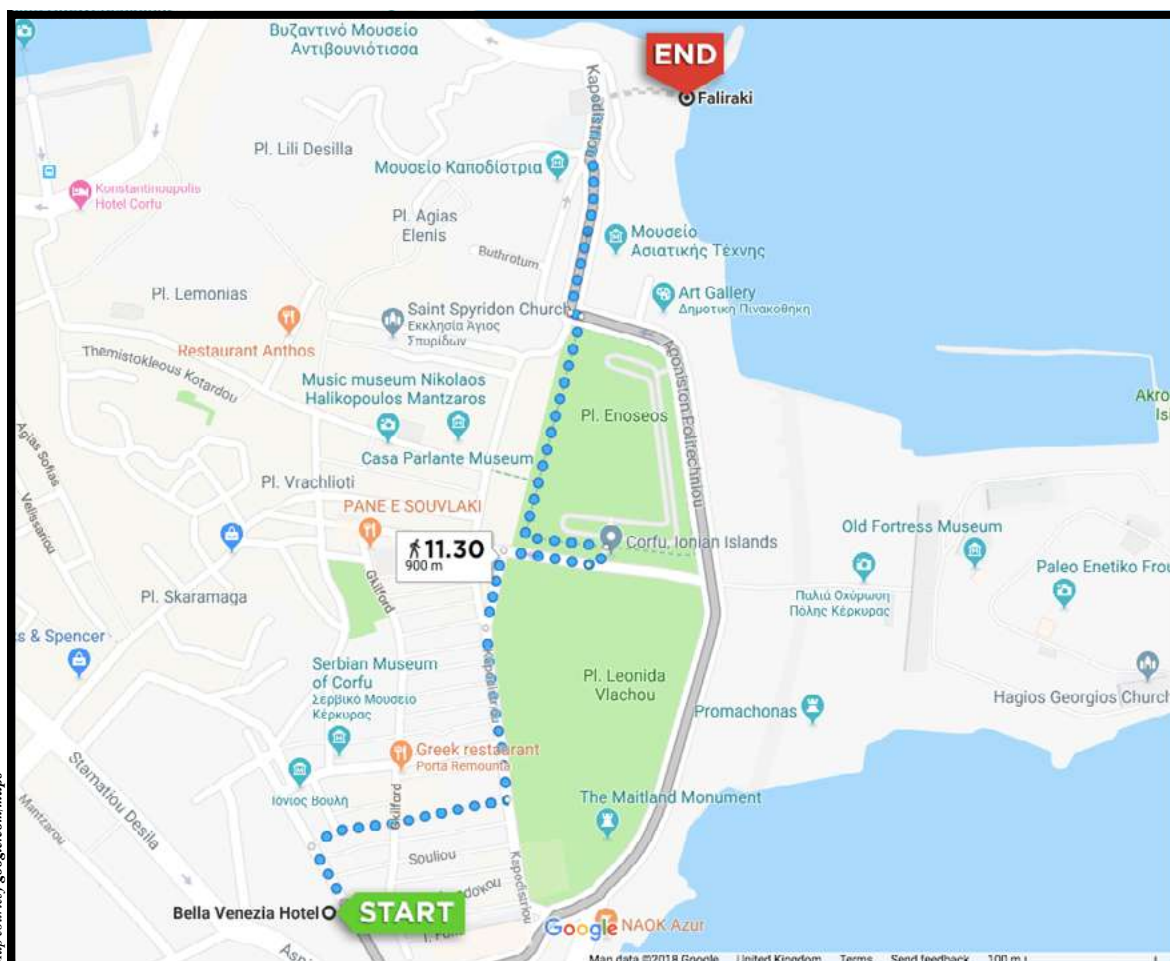

Map courtesy google.com/maps



Walking in Corfu, Greece (Morning)

From Hotel Bella Venezia to Faliraki pier

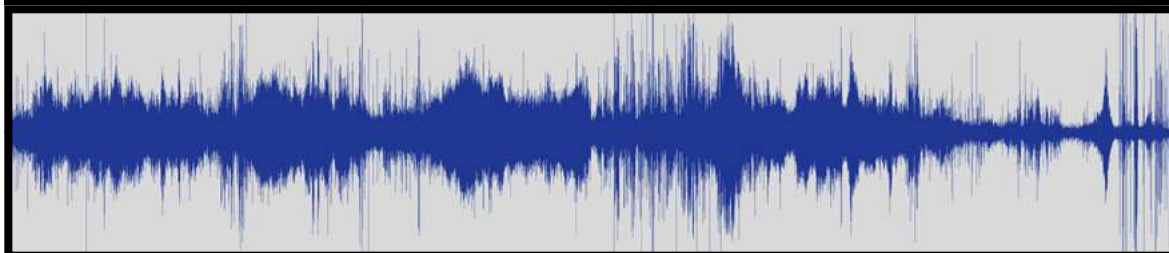
6 October 2011 • *Digital audio recording* • 11.30

OBJECT 2

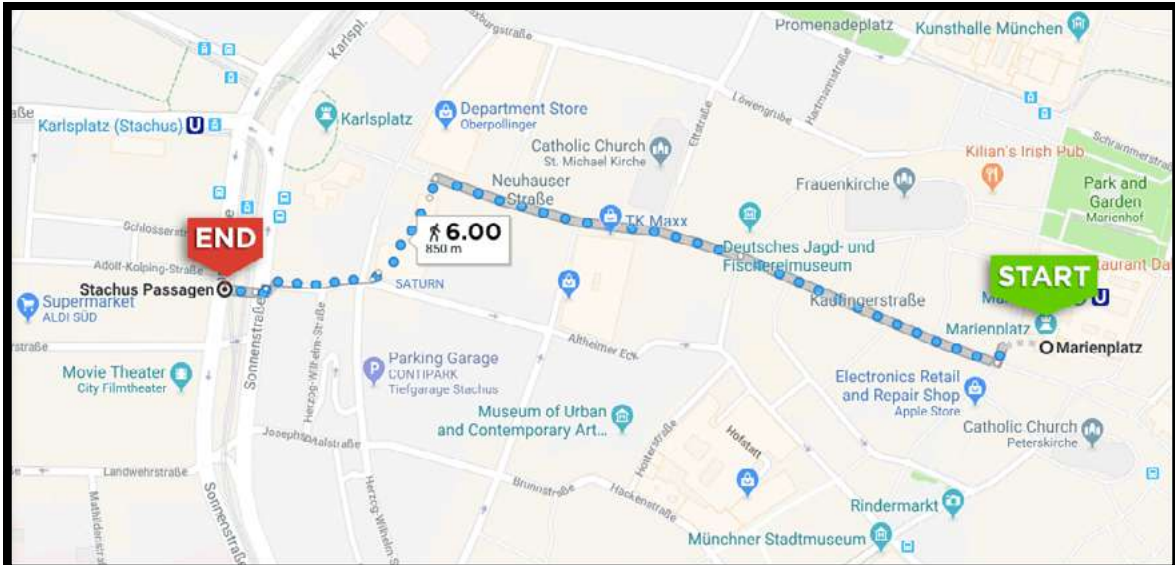

Walking in Munich, Germany (Night)

From Marienplatz through the underground to Sonnenstrasse
21 October 2012 • *Digital audio recording* • 6.00

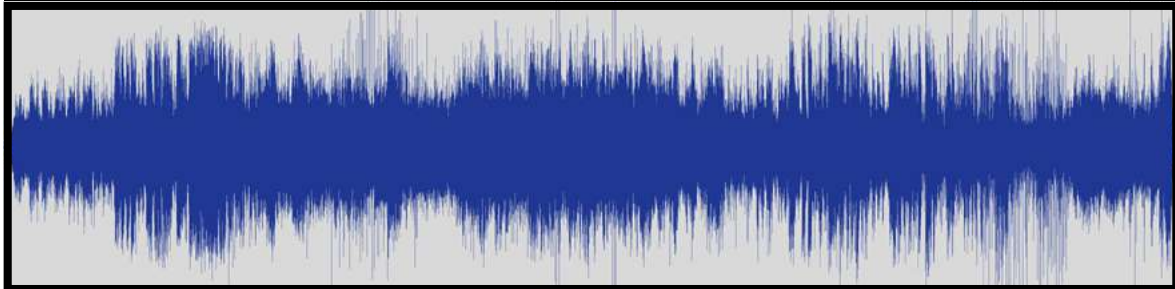

Do you have a habit of strolling around aimlessly? You might just be a philosopher in disguise.

Our Curator can tell you about **the Flâneur** – a term coined by Baudelaire to describe someone who wanders around with an inherent sense of curiosity!



OBJECT 3

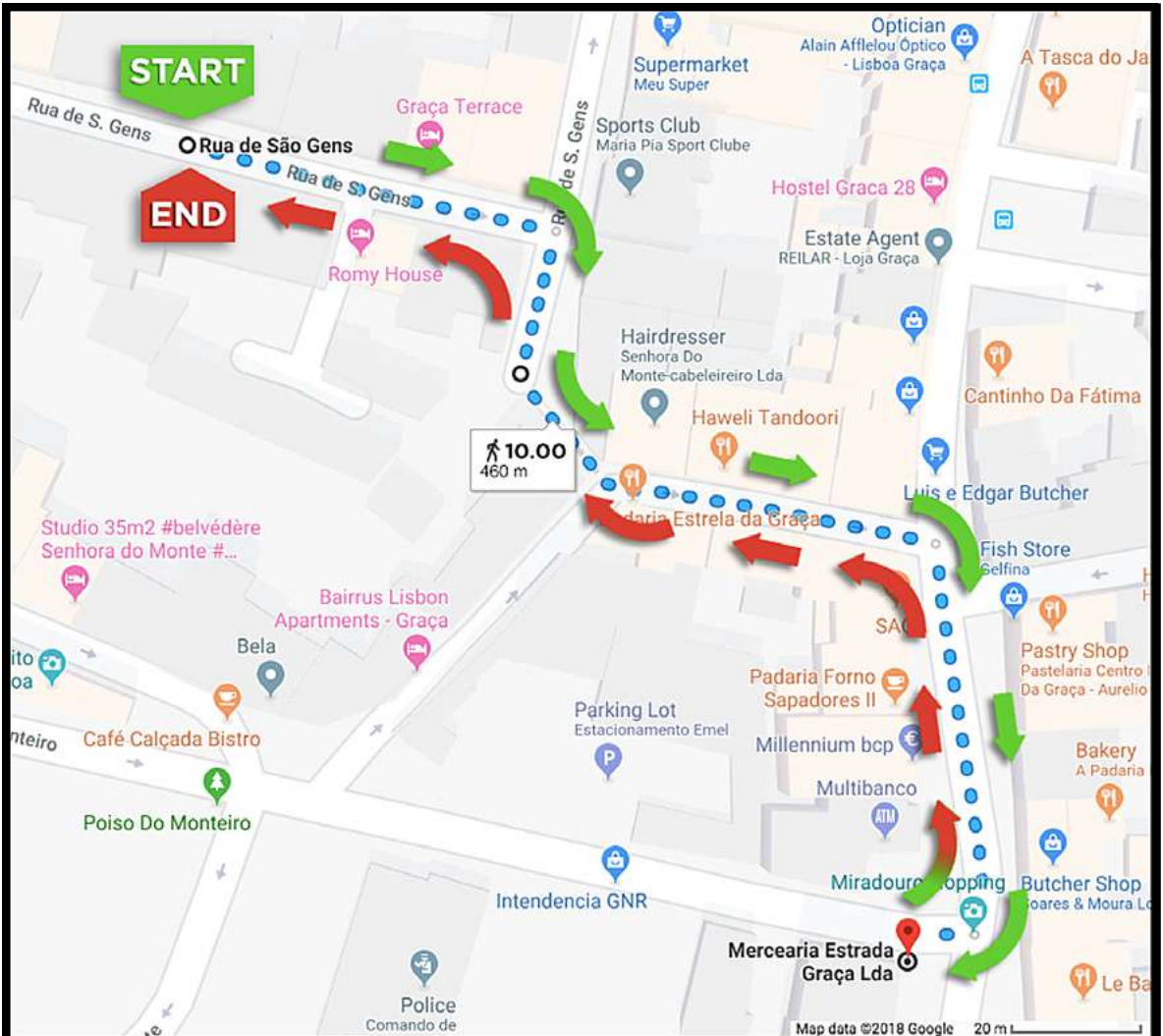

Map courtesy google.com/maps



Walking in Graça, Lisbon, Portugal (Morning)

From Rua de São Gens to Mercearia Estrada and back again

11 April 2015 • *Digital audio recording* • 10.00



OBJECT 4

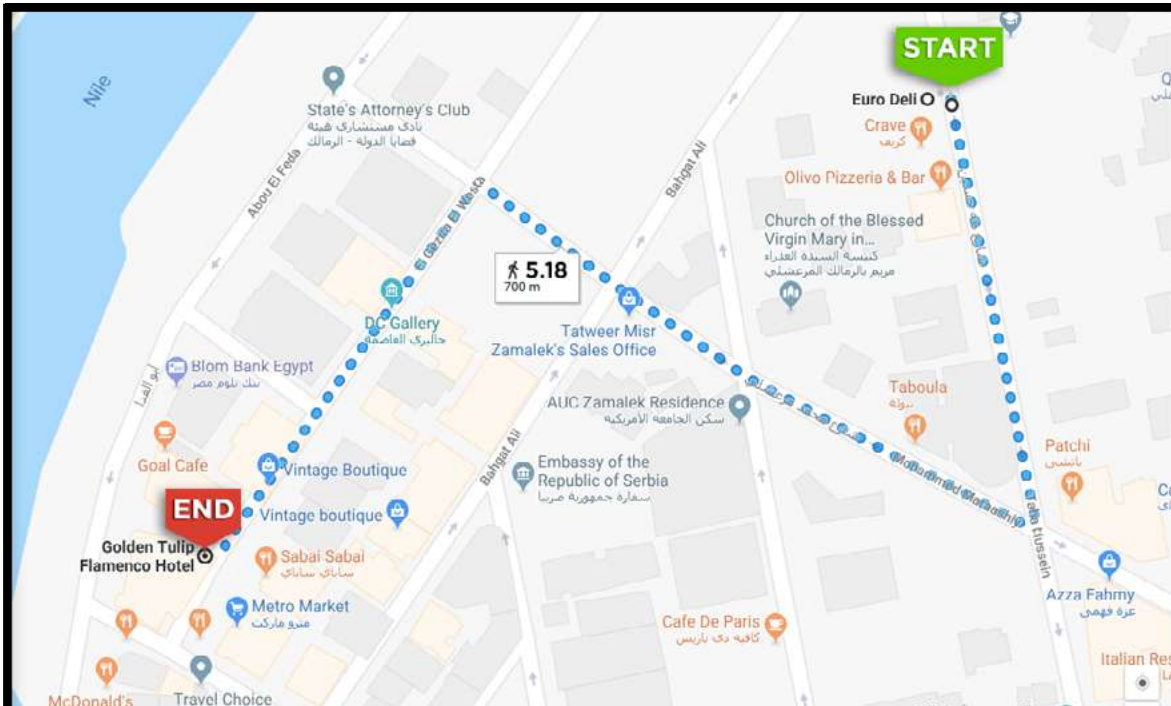

Map courtesy google.com/maps



Walking in Zamalek, Cairo, Egypt (Afternoon)

From EuroDeli to the Golden Tulip Flamenco Hotel

1 May 2010 • *Digital audio recording* • 5.18

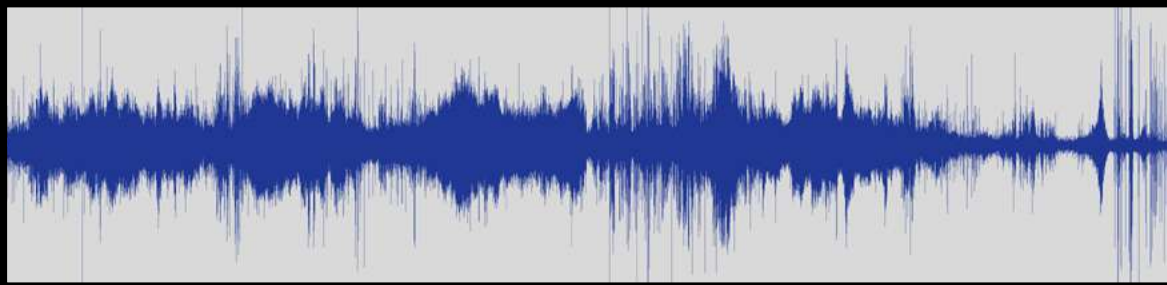

ART & CULTURE

Archaeology

DURATION 12 minutes 

22

- 01 **King Tutankhamun's Trumpets** Egyptian Museum, Cairo (16 Apr 1939)
- 02 **North Temple Interior** Karanis, Egypt (19 May 2010)
- 03 **Catacombs of Kom El Shaoufa** Alexandria, Egypt (11 May 2010)
- 04 **Archaeologists Clearing Roman Theatre** Lisbon, Portugal (9 Apr 2015)
- 05 **Ancient Roman Well** San Clemente, Rome (13 Apr 2017)
- 06 **Ancient Roman Channel** Winchester, UK (1 Aug 2018)



What behind-the-scenes disaster almost prevented King Tut's trumpets from ever being played?

What's it like to find yourself being pursued by a helicopter full of soldiers while inside an ancient Egyptian temple?

Our Curator can tell you some great stories about the objects in this gallery!



ART & CULTURE

Art Processes

23

DURATION 18 minutes 

- 01 **Millicent Fawcett Statue Unveiling (artist: Gillian Wearing)**
Parliament Square, London (24 April 2018)
- 02 **Drawing on Board (artist: Bettina Fung)** London (26 Sept 2016)
- 03 **Street Engraving (artist: unknown)** Cairo (17 May 2010)
- 04 **Street Artists Painting a Mural (artists: SOAK SK & Lefty Sketch)**
Southsea, UK (9 Sept 2018)
- 05 **Sculpting an Amphora (artist: Reem Gibriel)**
Ann Arbor, Michigan (31 Mar 2010)
- 06 **Constructing an Installation (artists: Christina Raab
and Jasmin Schaitl)** Warsaw (6 May 2017)
- 07 **Alley Weave: Loom (artist: unknown)** Varanasi, India (31 July 2009)
- 08 **Weaving, Loom (artist: Rachel Esslinger)**
Ann Arbor, Michigan (10 Oct 2009)
- 09 **Tree trimming (artist unknown)**
Mahmoud Mukhtar Park, Cairo (6 May 2010)
- 10 **Exhibition under construction (gallery workers: unknown)**
Ujazdowski Castle Centre for Contemporary Art, Warsaw (6 May 2017)

ART & CULTURE

Food

DURATION 20 minutes 

24

- 01 **Espresso** Rome, Italy (22 Apr 2017)
- 02 **Rice Krispies®** Facebook Live (14 Dec 2018)
- 03 **Lunch** Tandir Kebab, Baku, Azerbaijan (3 Oct 2017)
- 04 **Lunch** Café Olé Mallorca, Barcelona (18 Dec 2017)
- 05 **Food Court** Arkadia Shopping Mall, Cairo (2 May 2010)
- 06 **Oldest Coffee House in Europe** Oxford, UK (26 Aug 2018)
- 07 **Café Bräunerhof** Vienna (9 Dec 2017)
- 08 **Saganaki** Greek Town, Detroit (3 Nov 2009)
- 09 **Wine Service** Venice (21 May 2018)
- 10 **Pop Rocks®** London (6 June 2017)
- 11 **Cleaning Mercato di Rialto** Venice (23 May 2018)

Ever wonder how they say 'Snap, Crackle & Pop' in Germany? South Africa? Finland?

Our Curator has a whole collection of translations of the sounds of Rice Krispies® cereal from around the world!



Transport

25

DURATION **1 hour 29 minutes** 

INTER-CITY TRAINS

- 01 **Train To Cairo** Alexandria (12 May 2010)
- 02 **Amtrak Hiawatha Train** Chicago (Aug 2009)
- 03 **Night Train to Karlsruhe** Speyer, Germany (Aug 2012)
- 04 **Squeaking Metra Train** Chicago (March 2009)
- 05 **Southern Train to London** Portsmouth (2 April 2019)

INTRA-CITY TRAINS

- 06 **Tube to South Kensington** London (14 July 2018)
- 07 **Metro Train** Athens, Greece (1 Oct 2011)
- 08 **Red Line Train** Barcelona (2 Dec 2017)
- 09 **Holiday Train** Chicago (13 Dec 2008)
- 10 **Metro to Montmarte** Paris (25 Sept 2012)
- 11 **BART train to 24th Street** San Francisco (2 July 2008)
- 12 **Subway to Museum Station** Toronto (31 July 2009)
- 13 **Subway to Museumsquartier** Vienna (10 Dec 2017)

TRAMS & TROLLIES

- 14 **Antique Tram** Karlsruhe, Germany (16 Sept 2012)
- 15 **Tram to Rijksmuseum** Amsterdam (Feb 2010)
- 16 **Tram** Basel, Switzerland (25 Aug 2012)

- 17 **People Mover** Detroit (3 Nov 2009)
- 18 **Tram Approach** Minneapolis, Minnesota, US (Feb 2007)
- 19 **Tram** Strasbourg, France (Oct 2012)
- 20 **No. 26 Tram (wubbly)** Vienna (6 Dec 2017)
- 21 **Tram** Zagreb, Croatia (26 Sept 2015)
- 22 **No. 28 Trolley** Lisbon, Portugal (2 July 2008)
- 23 **Cable Car** San Francisco (31 July 2009)
- 24 **Trolley** Kenosha, Wisconsin, US (18 April 2009)

BUSES

- 25 **Number 9 Bus** Ann Arbor, Michigan, US (July 2009)
- 26 **Moaning Bus** Chicago (14 June 2008)
- 27 **316 Bus Through Bobadela** Lisbon, Portugal (22 Sept 2017)
- 28 **Bus to Ostiense Marconi** Rome (13 April 2017)

PRIVATE TRAVEL

- 29 **Harley Davidson Motorcycles** Milwaukee, US (31 Aug 2008)
- 30 **Cab Ride** Cairo (7 May 2010)

WATER TRAVEL

- 31 **Paddle Boat** Gallup Park, Ann Arbor (29 June 2010)
- 32 **Boat to Nilometer** Nile River, Cairo (15 May 2010)
- 33 **Disco Boat** Nile River, Cairo (17 May 2010)
- 34 **Water Taxi** Lake Michigan, Chicago (8 Sept 2008)
- 35 **Ferry Boat** Pelee Island, Canada (2 July 2010)
- 36 **Water Bus** Venice (22 May 2018)
- 37 **Canal Boat** Venice (2 Nov 2014)

AIR TRAVEL

- 38 **Flight Prep & Takeoff**
Baku, Azerbaijan –
London (7 Oct 2017)



SIGHTSEEING

- 39 **Horse-drawn Carriages** Warsaw, Poland (8 May 2017)
- 40 **Miniature Steam Train** Schloss Park, Karlsruhe (7 Sept 2012)
- 41 **Funicular** Zagreb, Croatia (26 Sept 2015)
- 42 **Bica Funicular** Lisbon, Portugal (26 Sept 2015)

ART & CULTURE

Bells & Clocks

DURATION 17 minutes 

25

- 01 **Munich Dom** Munich (21 Oct 2012)
- 02 **Heiliggeistkirche** Heidelberg, Germany (15 Sept 2012)
- 03 **Maulbronn Monastery Cloisters** Maulbronn, Germany (31 Aug 2012)
- 04 **Ghent Belfry** Ghent, Belgium (23 July 2017)
- 05 **Paletero Popsicle Cart** Albany Park, Chicago (10 May 2008)
- 06 **Westminster Abbey** London (Christmas Day 2014)
- 07 **Samuels Clock** Market Street, San Francisco (5 July 2008)
- 08 **Sagrada Familia** Barcelona (18 Dec 2017)
- 09 **Wedding Bells** Zagreb, Croatia (26 Sept 2015)
- 10 **St Geremia Tower Clock** Treviso, Venice (23 May 2018)
- 11 **Big Ben's Final 12 Bongs** London (8 August 2017)

ART & CULTURE

Rituals & Events

DURATION 1 hour & 10 minutes 

27

- 01 **Call to Prayer** Talaat Harb Street, Cairo (26 May 2010)
- 02 **Madhavi** Gurgaon, India (9 Sept 2016)
- 03 **Chanting** Al-Azhar Mosque: Cairo (21 May 2010)
- 04 **Sunday Services** Munich Dom church, Munich (21 Oct 2012)
- 05 **Public Water Fountain** Corfu, Greece (7 Oct 2011)
- 06 **Pub Worker Sweeping Street** Chez Paul II, Appenweier (8 Sept 2012)
- 07 **Hofbrauhaus** Munich, Germany (21 Oct 2012)
- 08 **Penny Arcade** Brighton Pier, Brighton, UK (1 Dec 2013)
- 09 **Carousel** Santa Cruz Boardwalk, California (5 July 2008)
- 10 **Roller Coaster** Centreville Island, Toronto (1 Aug 2009)
- 11 **World's Oldest Bookshop** Livraria Bertrand, Lisbon (8 June 2016)
- 12 **Street Market** Cairo (8 May 2010)
- 13 **Feira Da Ladra Flea Market** Lisbon (11 Apr 2015)
- 14 **Shop Owners Banter** Stratford Centre, London (26 Nov 2013)
- 15 **Amolador Trumpet** Lisbon (22 Aug 2017)
- 16 **Bird Whistle Salesman** Brighton, UK (1 Dec 2013)
- 17 **Wedding Musicians Practicing** Maulbronn Monastery (31 Aug 2012)
- 18 **Pride Parade** San Francisco (6 July 2008)
- 19 **Armistice Day Silence** Portsmouth & London (11 Nov 2018)

- 20 **Queen's Day (Koninginnedag)** Amsterdam (30 April 2011)
- 21 **Friday Night Down The Pub** London (28 Sept 2018)
- 22 **Classic Cars Showcase** Ypsilanti, Michigan, US (30 July 2009)
- 23 **Undercroft Skateboarding** Southbank Centre, London (5 Aug 2018)
- 24 **Chicago White Sox Stadium** Chicago (15 Feb 2007)
- 25 **Running Softball Bases** West Park, Ann Arbor, US (25 Sept 2009)
- 26 **Zamboni** Red Arrow Park, Milwaukee, US (5 Feb 2000)
- 27 **Busking Band** Underground District Line, London (18 Mar 2017)
- 28 **Bagpipe Busker** Selfridges, London (25 Nov 2013)
- 29 **Mira (Street Music, Crete)** Athens, Greece (1 Oct 2011)
- 30 **Violin vs Construction Saw** Barcelona (16 Dec 2017)
- 31 **Violin Busker** Ghent (4 Aug 2017)
- 32 **Duelling Buskers** South Bank, London (3 Oct 2014)
- 33 **Friday Of Departure (Egyptian Revolution Protest)** Alexandria (11 Feb 2011)
- 34 **Anti-Austerity Protest** Corfu, Greece (5 Oct 2011)
- 35 **Time's Up Protest** London (8 Jan 2018)
- 36 **Women's March Against Trump** London (14 July 2018)
- 37 **4th of July Fireworks** Albany Park, Chicago (2008)
- 38 **Flagpoles** Duderstadt Center, Ann Arbor, US (15 Feb 2010)
- 39 **Pere Lachaise Cemetery** Paris (30 Sept 2012)

Protests are a way for people to make their voice heard.

Our Curator can tell you lots more about the sounds of protest – ask away!



Libraries & Archives

DURATION 18 minutes 

28

- 01 **Bibliotheca Alexandrina** Alexandria, Egypt (10 May 2010)
- 02 **Bodleian Library** Oxford, UK (2 Sept 2018)
- 03 **New York Public Library Reading Room** (30 Mar 2008)
- 04 **Harold Washington Library Reference Room** Chicago (14 June 2009)
- 05 **Tampere Music Library** Tampere, Finland (13 June 2018)
- 06 **Museo di Storia Naturale di Venezia Bibliothec** Venice (24 May 2018)
- 07 **Kelsey Museum of Archaeology Archives** Ann Arbor (Feb 2012)
- 08 **Melodic CD-R Printer** British Library Sound Archive, London (2014)
- 09 **Internet Archive Backup**
Bibliotheca Alexandrina, Alexandria, Egypt (10 May 2010)
- 10 **Science Museum Sound Archives** Blythe House, London (23 Apr 2015)

- 01 **Acropolis Museum** Athens (November 2010)
- 02 **Ashmolean Museum** Oxford, UK (October 2015)
- 03 **Museum of Mechanical Musical Machines** Setúbal, Portugal (Sept 2017)
- 04 **Old Grand Rapids Public Museum** Grand Rapids, Michigan (20 Mar 2010)
- 05 **Museum of Broken Relationships** Zagreb, Croatia (2015)
- 06 **Guildhall Museum (On Fire)** London (March 2014)
- 07 **Sistine Chapel** Rome (10 April 2017)
- 08 **ModeMuseum Martin Margiela Exhibition** Antwerp, Belgium (21 July 2017)
- 09 **Museu de Cera dos Descobrimentos** Lagos, Portugal (5 Sept 2017)
- 10 **Pollocks Toy Museum** London (26 July 2017)
- 11 **Mold-A-Rama® Machine** Field Museum, Chicago (1 Jan 2012)
- 12 **Souvenir Coin Pressing Machine** Pelee Island, Canada (2 July 2010)
- 13 **Hayward Gallery Ana Mendieta Exhibition** London (November 2013)
- 14 **Florence Nightingale Museum** London (8 Aug 2017)
- 15 **Las Vegas Pinball Hall of Fame and Players Museum** (Feb 2011)
- 16 **Musei Vaticani** Raphael, *School of Athens*, Rome (10 Apr 2017)
- 17 **The Barbican** Eames Gravity Xylophone, London (7 Nov 2015)
- 18 **Tinguely Museum** Basel, Switzerland (Sept 2012)
- 19 **Sir John Soane's Museum London** (23 Nov 2013)

- 20 **Art Institute of Chicago** (June 2009)
- 21 **Dachau Concentration Camp** Munich, Germany (October 2012)
- 22 **Royal Observatory Prime Meridian** Greenwich, UK (3 Nov 2017)
- 23 **Playing the Rosetta Stone** The British Museum (19 May 2018)
- 24 **Detroit Science Center** (29 Aug 2010)
- 25 **Moomin Museum** Tampere, Finland (14 June 2018)
- 26 **Motown Museum** Detroit, Michigan, US (2012)

GALLERY

ART & CULTURE

Exhibitions of Sounds

DURATION **4 minutes** ⌚

30

- 01 **Sound Art: Sound as a Medium of Art**
ZKM | Center for Art and Media, Karlsruhe, Germany (Oct 2012)
- 02 **Art or Sound** Fondazione Prada, Venice (3 Nov 2014)



**PLEASE EXIT
THROUGH THE GIFT SHOP AT
MUSEUMOFPORTABLESOUND.COM/GIFTSHOP**

**SPEAK TO STAFF FOR DETAILS
THANK YOU - PLEASE COME AGAIN**





EXPOSITION SPACE TEMPORARY EXHIBITIONS

Temporary exhibitions at the Museum of Portable Sound are presented in our Exposition Space gallery, which is housed within our ultra-post-modern FRANK GEHRY® COMMEMORATIVE WING, which opened to the public on 25 March 2018.



EXPOSITION SPACE
TEMPORARY EXHIBITION

SOUNDS OF EARTH



THE RECORD THAT WENT TO SPACE



EXHIBITION AUDIO PRODUCED BY NASA
PROVIDED BY OZMA RECORDS



In 1977, NASA launched a golden record into the stars. The records onboard the Voyager I and II spacecraft are now in interstellar space, so far the only objects made by human hands to reach beyond our own star system. The records – made of gold, designed to last for a billion years – contain sounds, music, and pictures from Earth.

A small group of people were responsible for their creation: **Carl Sagan, Linda Sagan, Tim Ferris, and Ann Druyan** were the initiators of the project in 1974. The sound engineer for the records was **Russ Payne**. John Lennon suggested adding his own producer **Jimmy Iovine** to the project, who twiddled some knobs during the mixing sessions but mostly hung out on the beach.

The project involved a lengthy search for sounds from archives and libraries, with assistance and contributions from many people, such as Smithsonian field recordist **Alan Lomax** and whale recordist **Roger Payne**.

But it was Ann Druyan who served as the project's overall creative director, and whose own EEG readings are heard at the end of the 12-minute sound essay she compiled entitled *The Sounds of the Earth* – a montage of sounds intended

to represent the Earth's entire history in a logarithmic rather than historical sequence, so that the contribution of humans to the acoustic environment of the Earth would not be compressed to a single blip since our time on the planet has been relatively short compared to its entire lifespan.

This exhibition presents Druyan's sound essay in its entirety. The team behind the Golden Record project published a book together in 1978, *Murmurs of Earth*, which details the making and contents of the records.



LEFT

One of the Voyager Golden Records.

FOLLOWING PAGE ABOVE
Voyager I.

All images courtesy of NASA.

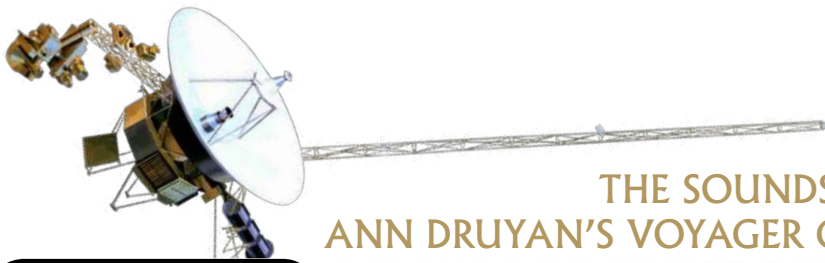

THE SOUNDS OF EARTH ANN DRUYAN'S VOYAGER GOLDEN RECORD PLAYLIST

00.00 - 00.45	Kepler's Harmony of the Worlds : Laurie Spiegel	
00.45 - 01.16	Volcanoes, Earthquake, Thunder	
01.16 - 01.30	Mud Pots	<i>As you listen, think about these questions:</i>
01.30 - 02.45	Wind, Rain, Surf	
02.45 - 04.00	Crickets, Frogs	<i>Do you think these sounds represent our whole planet?</i>
04.00 - 05.10	Birds, Hyena, Elephant	
05.10 - 05.22	Chimpanzee	
05.22 - 05.50	Wild Dog	
05.50 - 06.22	Footsteps, Heartbeat, Laughter	
06.22 - 06.27	Fire, Speech	<i>Which of these sounds would you leave off?</i>
06.27 - 06.42	The First Tools	
06.42 - 06.47	Tame Dog	
06.47 - 07.25	Herding Sheep, Birds, Blacksmith, Sawing	
07.25 - 07.44	Tractor, Riveter	
07.44 - 08.12	Morse Code ("Ad astra per aspera"*), Ships	
08.12 - 08.56	Horse and Cart	<i>What other sounds would you add?</i>
08.56 - 09.19	Train	
09.19 - 09.56	Tractor, Bus, Automobile	
09.56 - 11.00	F-111 Flyby, Saturn 5 Lift-off	
11.00 - 11.23	Kiss, Mother & Child	
11.23 - 12.19	EEG/Life Signs, Pulsar	

*Latin expression meaning "A rough road leads to the stars", more commonly phrased "Per aspera ad astra".

Staff Biographies

DIRECTOR & CHIEF CURATOR, MUSEUM OF PORTABLE SOUND



What my friends think I do



What museum professionals think I do



What I think I do



What sound artists think I do



What society thinks I do



What I really do

Dr John Kannenberg, MFA is a multimedia artist, writer, and researcher whose work investigates sounds as cultural objects; the multisensory geography of museums; the frontiers of digital heritage; the nexus between parody, authenticity, and the absurd; the phenomenology of time; and the importance of listening as a cultural, political, and empathic act.

John has appeared as a portable sound expert on BBC Four television's *How To Make* alongside Zoe Laughlin of the Institute of Making, and is a frequently invited speaker on the topic of sound and museums, appearing on BBC Radio 4; at the Victoria & Albert Museum; the Sackler Research Forum at the Courtauld Institute of Art; the Royal College of Art in London; The University College London Institute of Archaeology; London's National Gallery; the University for the Creative Arts, Farnham; Bournemouth Film School; John Cabot University in Rome; and the University of Leicester Museum Studies Programme. He was awarded the 2017 *Science Museum Group Journal* Writing Prize for his article about sounds as museological objects of culture.

His art practice emphasises process, rule-making, and rule-breaking. His work has been presented across the globe, including appearances at Tate Modern and the White Cube in London; Cairo's 100Live

festival; the First Glance video art festival in Tripoli; and Neighborhood Public Radio's project for the Whitney Biennial (duetting with Glenn Bach). John's drawings of the sounds of museum spaces have been published in Manifest Gallery's international drawing annual *INDAIO*, and his sound maps of museums have been featured on Hyperallergic.com.

John's independent curatorial work has included numerous exhibitions for radio, online and physical venues like Northwestern University's Herskovits Library of African Studies in Chicago; the ZKM Medienmuseum; the Biennale of Electronic Arts in Perth; London's ResonanceFM art radio station; and a permanent display of ancient Egyptian soundmaking objects for the University of Michigan's Kelsey Museum of Archaeology.

He also has an unhealthy addiction to Photoshop.

johnkannenberg.com

john@museumofportablesound.com

Contributors

DR LEAH BARCLAY

is an Australian sound artist, composer, and researcher known for acoustic ecology, environmental field recording, and sound walks. She is the president of the Australian Forum for Acoustic Ecology.

leahbarclay.com

JOÃO CALDAS

is an experimental knitter and textiles artist, as well as filthy south east London drag queen Ms Mary Poppers.

facebook.com/msmarypoppers

DR DANIEL CURLEY

is an Associate Professor of Classics and a poet. He lives in upstate New York.

CHRISTOPHER DELAURENTI

is a composer, improviser and phonographer. His electro-acoustic works are composed of field recordings and often deal with political issues, political protests in particular.

delaurenti.net

E GABRIEL EDVY

is a multi-disciplined artist and the owner of Blackswitch Labs.

egabrieledvy.com

blackswitchlabs.com

BEN FREETH

produces multichannel sound works, custom electronics, code, instruments and data driven artworks featuring sonification.

bcfreeth.wordpress.com

MIKE HALLENBECK

works in film, animation, ads, industrials, games, apps, and VR as a composer and sound editor/mixer.

juniorbirdman.com

KHALED KADDAL

is an artist who works between London (UK) and Alexandria (EG). His body of work encompasses a research-led approach, engaging with different mediums such as sound, moving image, and sculpture for installations and performances.

khaledkaddal.com

DR LAURA KLOEPPER

researches the sensory and behavioural processes underlying echolocation in toothed whales and microchiropteran bats, two suborders of mammals that convergently evolved echolocation.

laurakloepper.net

BETHANY LACKTORIN

is a performer, sound artist, and musician who creates site-specific, immersive, interactive, multi-disciplinary installation experiences that foster new perspectives, heightened awareness, and deeper connections to the spaces, places, and communities in which we live.

bethanylacktorin.org

CRISTINA SOUSA MARTÍNEZ

worked as the Museum of Portable Sound's Curatorial Assistant in 2016-2017 and is one of its most active supporters. She recently joined Magnum Photos, and continues to work on her own research projects.

DR HARRY WHALLEY

is a Belfast-born composer based in Scotland whose output includes Classical music, Jazz and Film Music.

harrywhalley.com



HELP SUPPORT THE UK'S #1 PORTABLE MUSEUM!



● **BECOME A PATRON**

Do you have a regular source of income that allows you the peace of mind to do the work you need to do?

Our museum would **LOVE** one of those!

If you value the work we do here at the Museum of Portable Sound and would like others to be able to experience what we do, please consider becoming our patron on Patreon.

For as little as **\$1 per month** you can help us cover basic costs like train fare to visits and events, printing of maps and Gallery Guides, facility rental, or a Physical Objects Collection acquisitions budget.



Go here now to support us:

patreon.com/museumofportablesound



ONLINE VISITOR GUIDE

Published by **Museum of Portable Sound Press**, Southsea, UK, PO5 3RL.

Designed, written, edited & produced by John Kannenberg unless otherwise credited.
Photography and illustration by John Kannenberg unless otherwise credited.

For the Museum of Portable Sound:

Director and Chief Curator

John Kannenberg

Trustees

Daniel Curley (*Saratoga Springs*)

CJ Mitchell (*Faversham*)

Board of Directors

Glenn Bach (*Los Angeles*)

Daniel Curley (*Saratoga Springs*)

Jono Gilmurray (*Bristol*)

Mike Hallenbeck (*Minneapolis*)

Annie Jamieson (*Bradford*)

Khaled Kaddal (*London/Alexandria*)

Meri Kytö (*Tampere*)

CJ Mitchell (*Faversham*)

Kwame Phillips (*Rome*)

Matthew Sansom (*Kuala Lumpur*)

Cheryl Tipp (*London*)

Paul Tourle (*London*)

S. Alana Wolf Johnson (*Rochester*)

Philip von Zweck (*Chicago*)

Special Thanks

Jessica Akerman

Leah Barclay

João Caldas

Paula Clemons

Karen Christopher

Michael DeBonis

Christopher DeLaurenti

Ekaterina Yonova-Doing

E Gabriel Edvy

Reed Esslinger

Ben Freeth

Bettina Fung

Reem Gibriel

Louise Gray

Mike Hallenbeck

Kris Hunt

Khaled Kaddal

Victoria Karlsson

Kathy Kercheck

Laura Kloepper

Bethany Lacktorin

Monika Lozinska

Ryan Patrick Maguire

Cristina Sousa Martínez

CJ Mitchell

Tom Parnell

Christina Raab

Matthew Sansom

Jasmin Schaitl

Cheryl Tipp

Lara Torres

Lydie Valentin

Harry Whalley

T.G. Wilfong

museumofportablesound.com

patreon.com/museumofportablesound

facebook.com/museumofportablesound

twitter.com/museumsound

instagram.com/museumofportablesound

youtube.com/c/museumofportablesound

museumofportablesound.bandcamp.com



WIRED

MARCH 2020



Still Not An App



MUSEUM **M.O.P.S.** OF PORTABLE SOUND

Personal Online Visits with The Chief Curator

Todd Rundgren 'TR-1' Talks CD-ROMs

Karlheinz Brandenburg 'MP3s Will Change The Way We Buy Music'

Bill Gates How A Global Pandemic Might Really Inconvenience You



MUSEUMOFPORTABLESOUND.COM/ONLINE